



SPHERICAL ROLLER BEARINGS CATALOGUE



Powered by



About us

Our company Zivko & Sinovi under the brand Z&S is specialized in fabrication of rolling bearings. Our biggest advantage is that our entire production cycle is under our control, from beginning to end so that we can ensure the best quality of our products.

Z&S Serbia is in a joint venture with the Z&R Chinese company, and from that the Z&R • Z&S corporation is born.

From raw materials to the final product, we possess all the equipment required for making the best quality bearings. Forging plant, Casting plant, Ball production plant, Sealing plants, Heat treatment equipment, Equipment for turning and grinding process, Assembly line and Laboratory for testing and ensuring quality.

Z&S Factories are located in China and Serbia, as well as our R&D Centers.



Facility Complex



Laboratory

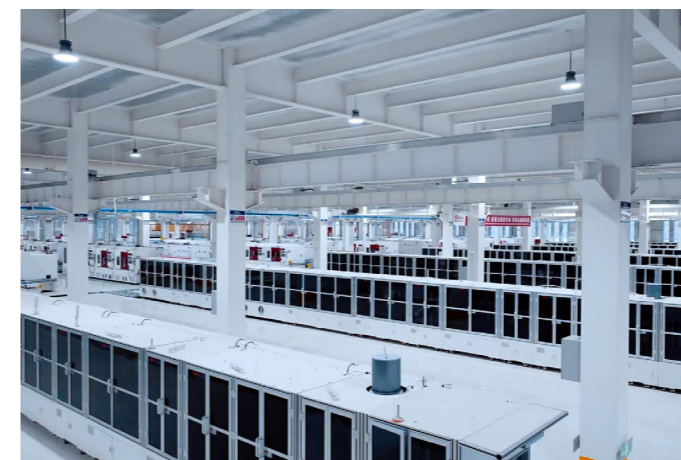

Production Lines



GENERAL INFORMATION Z&S BEARINGS

A. Dimensions and standards

- Rolling bearings are typically manufactured from high-quality chromium steel. Both the rings and rolling elements undergo heat treatment, achieving a standard hardness of 60–65 HRC and dimensional stability up to 120 °C. Bearing dimensions are precisely defined and standardized
- Symbols representing main dimensions of bearings have
- been standardized and are as follows:
 - d inside diameter
 - D outside diameter
 - B width of a radial bearing, for tapered roller bearings - width of an inner ring
 - C diameter of inner ring of a tapered roller bearing
 - H height of the thrust bearing
- All bearing boundary dimensions are defined in accordance with ISO 15, dimensional tolerances in accordance with ISO 492, internal clearances in accordance with ISO 5753-1, and dynamic and static load ratings are calculated in accordance with ISO 281 and ISO 76.

B. Accuracy classes

Rolling bearing tolerances define the accuracy classes for the main dimensions of the inner and outer rings, their geometrical form, and running accuracy—specifically, the relative positioning of the raceway, bore, outer diameter, and faces. These parameters are standardized by ISO. Based on the allowable deviations, the following accuracy classes are distinguished :

- P0 normal, not determined
- P6 higher than normal
- P5 higher than P6
- P4 higher than P5
- SP higher than P4 – super precision
- UP higher than SP – ultra precision

C. Clearance

Clearance refers to the relative displacement of one bearing ring with respect to the other. Depending on the direction of displacement, the following types of clearance are distinguished :

- Axial clearance – the maximum axial displacement of one ring relative to the other without applying any external load.
- Radial clearance – the maximum radial displacement of one ring relative to the other without applying any external load.

In most bearings (except, for example, angular-contact ball bearings), radial clearance is the more critical parameter and is therefore typically specified and indicated.

- C1 smaller than C2
- C2 smaller than normal
- normal is not to be marked
- C3 higher than normal
- C4 higher than C3
- C5 higher than C4

D. Silent-running bearings

The silent-running feature, also referred to as a reduced vibration level, applies to certain bearing designs intended for applications requiring quiet operation. The following symbols are used :

- normal is not marked
- C6 reduced vibration level
- C66 very low vibration level

Note : Symbols of accuracy class, radial clearance and vibrations levels can be combined.

E. Heat stability

- In applications where the continuous operating temperature of a bearing exceeds 120 °C, bearings subjected to special heat treatment for dimensional stabilization should be used. High temperatures negatively affect bearing performance in two ways: the steel expands, which can cause the bearing to seize, and at temperatures above 150 °C, the hardness of the hardened raceways decreases, leading to reduced load capacity and potential permanent deformation.

The following symbols are used to indicate the optimal bearing operating temperature ranges : Stability applies to both the inner and outer rings.

- S00 up to 120°C is not marked
- S0 up to 150°C
- S1 up to 200°C
- S2 up to 250°C
- S3 up to 300°C

GENERAL INFORMATION Z&S BEARINGS

F. Lubricating holes and grooves designations

- W20 lubricating holes in the outer bearing ring
- W26 lubricating holes in the internal bearing ring
- W33 lubricating groove and three lubricating holes in the outer bearing ring
- S as W33

G. Seals designations

- 2RS two rubber seals, two-sided covering

H. Designations regarding changes in outer dimensions or outer shape

- K standard tapered bore, with 1:12 taper
- K30 tapered bore with 1:30 taper, used for example with large dimensions

I. Designations regarding changes in inner construction

- C for spherical bearings – inner ring without lips

J. Cage designations

- M massive cage made of brass, sometimes stamped from sheet brass
- T cage made of thermohardening materials – textolite, solely for high-speed bearings
- TN, TN9, TVP, TVH, TNG cages made from thermoplastic materials – polyamide strengthened with glass fiber, sensitive for temperature over 100°C
- - Pressed steel cage

Bearing designations explained :

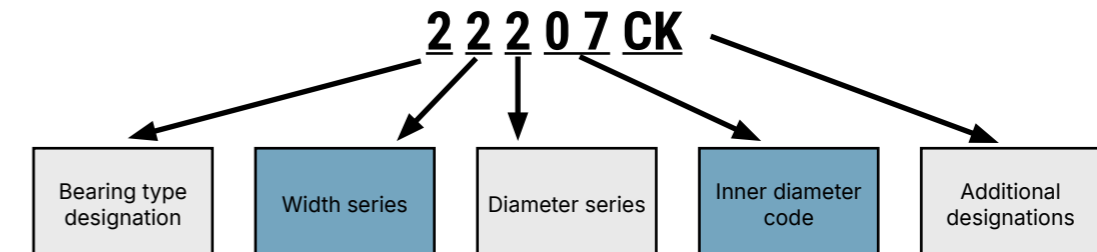

1. Bearing type designation
2. Numerical symbol of width series – only a width of a bearing
3. Numerical symbol of diameter series – size of a bearing
4. Numerical marking of an internal bearing diameter
5. Additional marking – tapered bore, angle, cage, seal, groove, accuracy classes, clearance, and the like.

1. Bearing type designations

The list of bearing types' designations and accessories that are subject to the standards mentioned above for the following catalogue :

- **2.. spherical bearings (five-digit symbol)**
- **H bearing sleeves**

2. Width series

- These symbols are not always indicated. Separate classifications apply to thrust bearings
- Width series diagram for radial bearings :

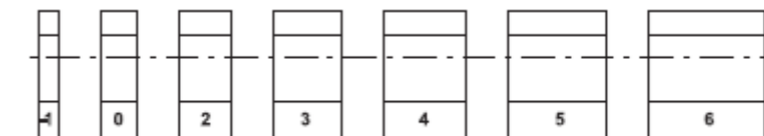

Each group has its own rules :

- for radial bearings the width series is put in the growing order: 1*, 0, (1), 2, 3, 4, 5, 6* (-1) series
- for thrust bearings it is called a height series and is put in the growing order 9, 1, 3 – single-direction

The width series number is not always specified

GENERAL INFORMATION Z&S BEARINGS

3. Diameter series

- The diameter series determines the overall bearing size. For a given internal diameter, changes in the diameter series affect both the outer diameter and the width of the bearing. Therefore, the diameter series is one of the most important elements of the bearing symbol, as it defines the relationship between all main bearing dimensions.

The diameter series symbol is always provided. Separate classifications apply to radial bearings, thrust bearings, and tapered bearings. Each group follows its own sequence :

- Radial bearings : 7, 8, 9, 0, 1, 2, 3, 4
- Thrust bearings : 1, 2, 3, 4

4. Designation "d" for internal bearing diameter

This element precisely defines the bearing's internal diameter in millimeters, using the system illustrated below. The marking rules are as follows :

- For internal diameters between 20 mm and 480 mm that are divisible by 5, the marking is obtained by dividing the actual size by 5. If the result is a single digit, a leading zero is added. For example : 20 mm → "04", 25 mm → "05", 50 mm → "10", and so on.
- For internal diameters above 480 mm, or for sizes not divisible by 5, the marking uses the "/" sign followed by the actual size, e.g., 500 mm → "/500", 22 mm → "/22".

5. Additional markings/designations

- tapered bore (K, K30)
- change in the inner construction (C)
- cage designation (M, T, TV, and so on)
- seal (2RS)
- lubricating holes and grooves (W20, W26, W33, S)
- accuracy class (P6, P5, P4, SP, UP)
- radial or axial clearance reduced (C2, C1) or increased (C3, C4, C5)
- silent-running feature – reduced vibration level (C6, C66)
- heat stability (S0, S1, S2, S3, S4, and so on).
- other markings regarding the type of lubricate, special features, etc.)

DYNAMIC AND STATIC BEARING LOADS

The dynamic and static load ratings for spherical roller bearings are calculated in accordance with ISO 281 for dynamic load ratings and ISO 76 for static load ratings, and the corresponding values for each bearing are provided in the product tables presented later in this catalogue.

For a more accurate determination of bearing service life considering the effects of bearing reliability, grease conditions and operating temperature, please contact the team at Z&S.

LOAD CARRYING ABILITY AND LIFE

The size of a bearing required for a specific arrangement is determined by the loads that will occur in the application and the required life needed for the application.

Variables known as load ratings are used in the bearing calculations as a measure of the load carrying ability:

- The basic dynamic load rating C and the basic static load rating C₀.
- The basic dynamic load rating is based on specifications determined in ISO 281 which the basic static load rating is based on specifications determined in ISO 76.

To select a bearing size, the basic rating life is typically calculated in accordance with ISO 281. The equation is:

$$L_{10} = \left(\frac{C}{P} \right)^{3.33}$$

If speed is constant, the basic rating life expressed in operating hours can be calculated using:

$$L_{10h} = \frac{1000000}{60 \times n} \times \left(\frac{C}{P} \right)^{3.33} \quad \text{or} \quad L_{10h} = \frac{1000000}{60 \times n} \times L_{10}$$

Where :

L₁₀ - basic rating life (at 90% reliability), millions of revolutions

L_{10h} - basic rating life (at 90% reliability), operating hours

C – basic dynamic load rating, kN

P – equivalent dynamic bearing load, kN

n – rotational speed, r/min

For a more accurate determination of bearing service life considering the effects of bearing reliability, grease conditions and operating temperature, please contact the team at Z&S.

BEARING AND SHAFT FITS

The fit of the bearing and shaft is based on the bore, while that of the bearing and housing is based on the shaft. The fit between the bearing and shaft is different from the tolerance fitting system applied in the manufacturing industry. consequently the bearing bore tolerance is usually in minus values.

Under those conditions, the fit is tighter than usual.

Shaft Nom. Diameter (mm)	Values	g6	h5	h6	j5	j6	k5	k6
> 6 to 10	Deviations	+5/+14	0/+6	0/+9	-3/+3	-4/+5	-6/0	-9/0
	Theoretical	+5/+22	0/+14	0/+17	-3/+11	-4/+13	-6/+8	-9/+8
	Probable	+7/+20	+2/+12	+2/+15	-1/+9	-2/+11	-4/+6	-7/+6
> 10 to 18	Deviations	+6/+17	0/+8	0/+11	-4/+4	-5/+6	-7/0	-10/+1
	Theoretical	+6/+25	0/+16	0/+19	-4/+12	-5/+14	-7/+8	-10/+9
	Probable	+8/+23	+2/+14	+2/+17	-2/+10	-2/+11	-5/+6	-7/+6
> 18 to 30	Deviations	+7/+20	0/+9	0/+13	-4/+5	-5/+8	-8/0	-11/+2
	Theoretical	+7/+29	0/+18	0/+22	-4/+14	-5/+17	-8/+9	-11/+11
	Probable	+10/+26	+2/+16	+3/+19	-2/+12	-2/+14	-6/+7	-8/+8
> 30 to 50	Deviations	+9/+25	0/+11	0/+16	-5/+6	-6/+10	-9/0	-13/+3
	Theoretical	+9/+36	0/+22	0/+27	-5/+17	-6/+21	-9/+11	-13/+14
	Probable	+12/+33	+3/+19	+3/+24	-2/+14	-2/+17	-6/+8	-9/+10
> 50 to 80	Deviations	+10/+29	0/+13	0/+19	-6/+7	-6/+13	-10/0	-15/+4
	Theoretical	+10/+42	0/+26	0/+32	-6/+20	-6/+26	-10/+13	-15/+17
	Probable	+14/+38	+3/+23	+4/+28	-2/+16	-2/+22	-7/+10	-11/+13
> 80 to 120	Deviations	+12/+34	0/+15	0/+22	-6/+9	-6/+16	-12/0	-18/+4
	Theoretical	+12/+54	0/+35	0/+42	-6/+29	-6/+36	-12/+23	-18/+24
	Probable	+16/+50	+4/+31	+4/+38	-2/+25	-2/+32	-8/+19	-13/+19

Shaft Nom. Diameter (mm)	Values	m6	m5	p6	p7	r6	r7	n6
> 6 to 10	Deviations	-15/-6	-12/-6	-24/-15	-28/-15	—	—	-19/-10
	Theoretical	-15/+2	-12/+2	-24/-7	-28/-7	—	—	-19/-2
	Probable	-13/-1	-10/-1	-22/-10	-26/-10	—	—	-17/-5
> 10 to 18	Deviations	-18/-7	-15/-7	-29/-18	-34/-18	—	—	-23/-12
	Theoretical	-18/+1	-15/+1	-29/-10	-34/-10	—	—	-23/-4
	Probable	-15/-2	-12/-2	-26/-13	-31/-13	—	—	-20/-7
> 18 to 30	Deviations	-21/-8	-17/-8	-35/-22	-41/-22	—	—	-28/-15
	Theoretical	-21/+1	-17/+1	-35/-13	-41/-13	—	—	-28/-6
	Probable	-18/-2	-14/-2	-32/-16	-38/-16	—	—	-25/-9
> 30 to 50	Deviations	-25/-9	-20/-9	-42/-26	-50/-26	-59/-43	-67/-43	-33/-17
	Theoretical	-25/+2	-20/+2	-42/-15	-50/-15	-59/-32	-67/-32	-33/-6
	Probable	-21/-2	-16/-2	-38/-19	-46/-19	-55/-36	-63/-36	-29/-10
> 50 to 80	Deviations	-30/-11	-24/-11	-51/-32	-62/-32	-72/-53	-83/-53	-39/-20
	Theoretical	-30/+2	-24/+2	-51/-19	-62/-19	-72/-40	-83/-40	-39/-7
	Probable	-26/-2	-20/-2	-47/-23	-58/-23	-68/-44	-79/-44	-35/-11
> 80 to 120	Deviations	-35/-13	-28/-13	-59/-37	-72/-37	-101/-79	-114/-79	-45/-23
	Theoretical	-35/+2	-28/+2	-59/-22	-72/-22	-101/-64	-114/-64	-45/-8
	Probable	-30/-3	-23/-3	-54/-27	-67/-27	-96/-69	-109/-69	-40/-13

BEARING AND SHAFT FITS

Shaft Nom. Diameter (mm)	Values	g6	h5	h6	j5	j6	k5	k6
> 120 to 150	Deviations	+14/+39	0/+18	0/+25	-7/+11	-7/+18	-14/0	-20/+5
	Theoretical	+14/+64	0/+43	0/+50	-7/+36	-7/+43	-14/+25	-20/+30
	Probable	+19/+59	+5/+38	+5/+45	-2/+31	-2/+38	-9/+20	-14/+24
> 150 to 180	Deviations	+14/+39	0/+18	0/+25	-7/+11	-7/+18	-14/0	-20/+5
	Theoretical	+14/+64	0/+43	0/+50	-7/+36	-7/+43	-14/+25	-20/+30
	Probable	+19/+59	+5/+38	+5/+45	-2/+31	-2/+38	-9/+20	-14/+24
> 180 to 250	Deviations	+15/+44	0/+20	0/+29	-7/+13	-7/+22	-15/0	-24/+5
	Theoretical	+15/+74	0/+50	0/+59	-7/+43	-7/+52	-15/+30	-24/+35
	Probable	+21/+68	+6/+44	+7/+52	-2/+38	-2/+47	-10/+25	-18/+29
> 250 to 315	Deviations	+17/+49	0/+23	0/+32	-7/+16	-7/+25	-17/0	-26/+9
	Theoretical	+17/+84	0/+58	0/+67	-7/+51	-7/+60	-17/+35	-26/+44
	Probable	+24/+77	+7/+51	+8/+60	-2/+46	-2/+55	-11/+29	-19/+37
> 315 to 400	Deviations	+18/+54	0/+25	0/+36	-7/+18	-7/+29	-18/0	-30/+11
	Theoretical	+18/+94	0/+65	0/+76	-7/+58	-7/+69	-18/+40	-30/+51
	Probable	+26/+86	+8/+57	+9/+67	-2/+53	-2/+64	-12/+34	-23/+44
> 400 to 500	Deviations	+20/+60	0/+27	0/+40	-7/+20	-7/+33	-20/0	-34/+12
	Theoretical	+20/+105	0/+72	0/+85	-7/+65	-7/+78	-20/+45	-34/+57
	Probable	+29/+96	+9/+63	+11/+74	-2/+60	-2/+73	-14/+39	-27/+50

Shaft Nom. Diameter (mm)	Values	m6	m5	p6	p7	r6	r7	n6
> 120 to 150	Deviations	-40/-15	-33/-15	-68/-43	-83/-43	-106/-81	-121/-81	-52/-27
	Theoretical	-40/+3	-33/+3	-68/-25	-83/-25	-106/-63	-121/-63	-52/-9
	Probable	-35/-3	-28/-3	-63/-30	-78/-30	-101/-68	-116/-68	-47/-14
> 150 to 180	Deviations	-40/-15	-33/-15	-68/-43	-83/-43	-134/-109	-149/-109	-52/-27
	Theoretical	-40/+3	-33/+3	-68/-25	-83/-25	-134/-91	-149/-91	-52/-9
	Probable	-35/-3	-28/-3	-63/-30	-78/-30	-129/-96	-144/-96	-47/-14
> 180 to 250	Deviations	-46/-17	-37/-17	-79/-50	-96/-50	-160/-131	-177/-131	-60/-31
	Theoretical	-46/+3	-37/+3	-79/-30	-96/-30	-160/-111	-177/-111	-60/-11
	Probable	-40/-3	-31/-3	-73/-36	-90/-36	-154/-117	-171/-117	-54/-17
> 250 to 315	Deviations	-52/-20	-43/-20	-88/-56	-108/-56	-170/-138	-190/-138	-66/-34
	Theoretical	-52/+5	-43/+5	-88/-31	-108/-31	-170/-113	-190/-113	-66/-9
	Probable	-45/-2	-36/-2	-81/-38	-101/-38	-163/-120	-183/-120	-59/-16
> 315 to 400	Deviations	-57/-21	-46/-21	-98/-62	-119/-62	-179/-143	-200/-143	-73/-37
	Theoretical	-57/+9	-46/+9	-98/-32	-119/-32	-179/-113	-200/-113	-73/-7
	Probable	-50/0	-39/0	-91/-39	-112/-39	-172/-120	-193/-120	-66/-14
> 400 to 500	Deviations	-62/-23	-50/-23	-108/-69	-131/-69	-194/-155	-217/-155	-80/-41
	Theoretical	-62/+12	-50/+12	-108/-34	-131/-34	-194/-120	-217/-120	-80/-6
	Probable	-54/+4	-42/+4	-100/-42	-123/-42	-186/-128	-209/-128	-72/-14

HOUSING AND SHAFT FITS

Housing Nom. Diameter (mm)	Values	F7	G7	H8	H7	H6
> 6 to ≤ 10	Deviations	+13 / +28	+5 / +20	0 / +22	0 / +15	0 / +9
	Theoretical	+13 / +36	+5 / +28	0 / +30	0 / +23	0 / +17
	Probable	+16 / +33	+8 / +25	+3 / +27	+3 / +20	+2 / +15
> 10 to ≤ 18	Deviations	+16 / +34	+6 / +24	0 / +27	0 / +18	0 / +11
	Theoretical	+16 / +42	+6 / +32	0 / +35	0 / +26	0 / +19
	Probable	+19 / +39	+9 / +29	+3 / +32	+3 / +23	+2 / +17
> 18 to ≤ 30	Deviations	+20 / +41	+7 / +28	0 / +33	0 / +21	0 / +13
	Theoretical	+20 / +50	+7 / +37	0 / +42	0 / +30	0 / +22
	Probable	+23 / +47	+10 / +34	+3 / +39	+3 / +27	+3 / +19
> 30 to ≤ 50	Deviations	+25 / +50	+9 / +34	0 / +39	0 / +25	0 / +16
	Theoretical	+25 / +61	+9 / +45	0 / +50	0 / +36	0 / +27
	Probable	+29 / +57	+13 / +41	+5 / +45	+5 / +31	+3 / +24
> 50 to ≤ 80	Deviations	+30 / +60	+10 / +40	0 / +46	0 / +30	0 / +19
	Theoretical	+30 / +73	+10 / +53	0 / +59	0 / +43	0 / +32
	Probable	+35 / +68	+15 / +48	+5 / +54	+5 / +38	+4 / +28
> 80 to ≤ 120	Deviations	+36 / +71	+12 / +47	0 / +54	0 / +35	0 / +22
	Theoretical	+36 / +86	+12 / +62	0 / +69	0 / +50	0 / +37
	Probable	+41 / +81	+17 / +57	+7 / +62	+7 / +43	+5 / +32
> 120 to ≤ 150	Deviations	+43 / +83	+14 / +54	0 / +63	0 / +40	0 / +25
	Theoretical	+43 / +101	+14 / +72	0 / +81	0 / +58	0 / +43
	Probable	+50 / +94	+21 / +65	+7 / +74	+7 / +51	+6 / +37
> 150 to ≤ 180	Deviations	+43 / +83	+14 / +54	0 / +63	0 / +40	0 / +25
	Theoretical	+43 / +108	+14 / +79	0 / +88	0 / +65	0 / +50
	Probable	+51 / +100	+22 / +71	+9 / +79	+8 / +57	+7 / +43
> 180 to ≤ 250	Deviations	+50 / +96	+15 / +61	0 / +72	0 / +46	0 / +29
	Theoretical	+50 / +126	+15 / +91	0 / +102	0 / +76	0 / +59
	Probable	+60 / +116	+25 / +81	+11 / +91	+10 / +66	+8 / +51
> 250 to ≤ 315	Deviations	+56 / +108	+17 / +69	0 / +81	0 / +52	0 / +32
	Theoretical	+56 / +143	+17 / +104	0 / +116	0 / +87	0 / +67
	Probable	+68 / +131	+29 / +92	+13 / +103	+12 / +75	+9 / +58
> 315 to ≤ 400	Deviations	+62 / +119	+18 / +75	0 / +89	0 / +57	0 / +36
	Theoretical	+62 / +159	+18 / +115	0 / +129	0 / +97	0 / +76
	Probable	+75 / +146	+31 / +102	+15 / +114	+13 / +84	+11 / +65
> 400 to ≤ 500	Deviations	+68 / +131	+20 / +83	0 / +97	0 / +63	0 / +40
	Theoretical	+68 / +176	+20 / +128	0 / +142	0 / +108	0 / +85
	Probable	+83 / +161	+35 / +113	+17 / +125	+15 / +93	+12 / +73

M6	J6	J7	K6	K7	Housing Nom. Diameter (mm)
-12 / -3	-4 / +5	-6 / +9	-9 / 0	-12 / +3	> 6 to ≤ 10
-12 / +5	-4 / +13	-6 / +17	-9 / +8	-12 / +11	
-10 / +3	-2 / +11	-3 / +14	-7 / +6	-9 / +8	
-15 / -4	-5 / +6	-7 / +11	-10 / +1	-15 / +3	> 10 to ≤ 18
-15 / +4	-5 / +14	-7 / +19	-10 / +9	-15 / +11	
-13 / +2	-2 / +11	-4 / +16	-7 / +6	-12 / +8	
-17 / -4	-5 / +8	-9 / +12	-11 / +2	-18 / +3	> 18 to ≤ 30
-17 / +5	-5 / +17	-9 / +21	-11 / +11	-18 / +12	
-14 / +2	-2 / +14	-5 / +17	-8 / +8	-14 / +8	
-20 / -4	-6 / +10	-11 / +14	-13 / +3	-21 / +4	> 30 to ≤ 50
-20 / +7	-6 / +21	-11 / +25	-13 / +14	-21 / +15	
-17 / +4	-2 / +17	-7 / +21	-9 / +10	-17 / +11	
-24 / -5	-6 / +13	-12 / +18	-15 / +4	-25 / +5	> 50 to ≤ 80
-24 / +8	-6 / +26	-12 / +31	-15 / +17	-25 / +18	
-20 / +4	-2 / +22	-6 / +25	-11 / +13	-19 / +12	
-28 / -6	-6 / +16	-13 / +22	-18 / +4	-30 / +5	> 80 to ≤ 120
-28 / +9	-6 / +31	-13 / +37	-18 / +19	-30 / +20	
-23 / +4	-1 / +26	-6 / +30	-13 / +14	-23 / +13	
-33 / -8	-7 / +18	-14 / +26	-21 / +4	-35 / +5	> 120 to ≤ 150
-33 / +10	-7 / +36	-14 / +44	-21 / +22	-35 / +23	
-27 / +4	-1 / +30	-6 / +36	-15 / +16	-27 / +15	
-33 / -8	-7 / +18	-14 / +26	-21 / +4	-35 / +5	> 150 to ≤ 180
-33 / +17	-7 / +43	-14 / +51	-21 / +29	-35 / +30	
-27 / +11	0 / +36	-4 / +41	-11 / +19	-25 / +20	
-37 / -8	-7 / +22	-16 / +30	-24 / +5	-40 / +6	> 180 to ≤ 250
-37 / +22	-7 / +52	-16 / +60	-24 / +35	-40 / +36	
-29 / +14	+1 / +44	-4 / +48	-13 / +24	-29 / +25	
-41 / -9	-7 / +25	-16 / +36	-27 / +5	-46 / +6	> 250 to ≤ 315
-41 / +26	-7 / +60	-16 / +71	-27 / +40	-46 / +41	
-32 / +17	+2 / +51	-1 / +56	-14 / +27	-33 / +28	
-46 / -10	-7 / +29	-18 / +39	-29 / +7	-50 / +7	> 315 to ≤ 400
-46 / +30	-7 / +69	-18 / +79	-29 / +47	-50 / +47	
-36 / +19	+4 / +58	-1 / +62	-14 / +32	-35 / +32	
-50 / -10	-7 / +33	-20 / +43	-32 / +8	-57 / +6	> 400 to ≤ 500
-50 / +35	-7 / +78	-20 / +88	-32 / +53	-57 / +51	
-38 / +23	+5 / +66	0 / +68	-15 / +36	-40 / +34	

HOUSING AND SHAFT FITS

Housing Nom. Diameter (mm)	Values	M7	N6	N7	P6	P7
> 6 to ≤ 10	Deviations	-15 / 0	-16 / -7	-19 / -4	-21 / -12	-24 / -9
	Theoretical	-15 / +8	-16 / +1	-19 / +4	-21 / -4	-24 / -1
	Probable	-12 / +5	-14 / -1	-16 / +1	-19 / -6	-21 / -4
> 10 to ≤ 18	Deviations	-18 / 0	-20 / -9	-23 / -5	-26 / -15	-29 / -11
	Theoretical	-18 / +8	-20 / -1	-23 / +3	-26 / -7	-29 / -3
	Probable	-15 / +5	-18 / -3	-20 / 0	-24 / -9	-26 / -6
> 18 to ≤ 30	Deviations	-21 / 0	-24 / -11	-28 / -7	-31 / -18	-35 / -14
	Theoretical	-21 / +9	-24 / -2	-28 / +2	-31 / -9	-35 / -5
	Probable	-18 / +6	-21 / -5	-25 / -1	-28 / -12	-32 / -8
> 30 to ≤ 50	Deviations	-25 / 0	-28 / -12	-33 / -8	-37 / -21	-42 / -17
	Theoretical	-25 / +11	-28 / -1	-33 / +3	-37 / -10	-42 / -6
	Probable	-21 / +7	-25 / -4	-29 / -1	-34 / -13	-38 / -10
> 50 to ≤ 80	Deviations	-30 / 0	-33 / -14	-39 / -9	-45 / -26	-51 / -21
	Theoretical	-30 / +13	-33 / -1	-39 / +4	-45 / -13	-51 / -8
	Probable	-25 / +8	-29 / -5	-34 / -1	-41 / -17	-46 / -13
> 80 to ≤ 120	Deviations	-35 / 0	-38 / -16	-45 / -10	-52 / -30	-59 / -24
	Theoretical	-35 / +15	-38 / -1	-45 / +5	-52 / -15	-59 / -9
	Probable	-30 / +10	-33 / -6	-40 / 0	-47 / -20	-54 / -14
> 120 to ≤ 150	Deviations	-40 / 0	-45 / -20	-52 / -12	-61 / -36	-68 / -28
	Theoretical	-40 / +18	-45 / -2	-52 / +6	-61 / -18	-68 / -10
	Probable	-33 / +11	-39 / -8	-45 / -1	-55 / -24	-61 / -17
> 150 to ≤ 180	Deviations	-40 / 0	-45 / -20	-52 / -12	-61 / -36	-68 / -28
	Theoretical	-40 / +25	-45 / +5	-52 / +13	-61 / -11	-68 / -3
	Probable	-33 / +17	-38 / -2	-44 / +5	-54 / -18	-60 / -11
> 180 to ≤ 250	Deviations	-46 / 0	-51 / -22	-60 / -14	-70 / -41	-79 / -33
	Theoretical	-46 / +30	-51 / +8	-60 / +16	-70 / -11	-79 / -3
	Probable	-36 / +20	-43 / 0	-50 / +6	-62 / -19	-69 / -13
> 250 to ≤ 315	Deviations	-52 / 0	-57 / -25	-66 / -14	-79 / -47	-88 / -36
	Theoretical	-52 / +35	-57 / +10	-66 / +21	-79 / -12	-88 / -1
	Probable	-41 / +23	-48 / +1	-54 / +9	-70 / -21	-76 / -13
> 315 to ≤ 400	Deviations	-57 / 0	-62 / -26	-73 / -16	-87 / -51	-98 / -41
	Theoretical	-57 / +40	-62 / +14	-73 / +24	-87 / -11	-98 / -1
	Probable	-44 / +27	-51 / +3	-60 / +11	-76 / -22	-85 / -14
> 400 to ≤ 500	Deviations	-63 / 0	-67 / -27	-80 / -17	-95 / -55	-108 / -45
	Theoretical	-63 / +45	-67 / +18	-80 / +28	-95 / -10	-108 / 0
	Probable	-48 / +30	-55 / +6	-65 / +13	-83 / -22	-93 / -15

- GENERAL INFORMATION Z&S BEARINGS..... 4**
- DYNAMIC AND STATIC BEARING LOADS..... 8**
- LOAD CARRYING ABILITY AND LIFE 9**
- BEARING AND SHAFT FITS 10**
- HOUSING AND SHAFT FITS..... 14**
- 1. SPHERICAL ROLLER BEARINGS 18**
- 1.1 SINGLE-ROW AND DOUBLE-ROW SPHERICAL ROLLER BEARINGS20**
- 20-50 MM.....20**
- 50-75 MM.....22**
- 75-100 MM24**
- 100-120 MM26**
- 120-150 MM28**
- 150-170 MM30**
- 180-200 MM32**
- 200-260 MM34**
- 260-300 MM36**
- 1.2 SPHERICAL ROLLER BEARINGS WITH ADAPTER SLEEVE38**
- 20-70 MM.....38**
- 75-135 MM40**
- 135-240 MM42**
- 240-300 MM44**
- 2. SPHERICAL ROLLER THRUST BEARINGS..... 46**
- 2.1 SPHERICAL ROLLER THRUST BEARINGS.....48**
- 60-240 MM48**
- 240-380 MM50**

1. SPHERICAL ROLLER BEARINGS

A. Dimension series

- 202.. 203.. - single-row with cylindrical bore
- 202 K.. 203 K.. - single-row with tapered bore (1:12)
- 238.. 239.. 230.. 240.. 231.. 241.. 222.. 232.. 223.. 233.. - double-row with cylindrical bore
- 238..K 239..K 230..K 231..K 222..K 232..K 223..K 233.. - double-row with tapered bore (1:12)
- 240..K30 241..K30 - double-row with tapered bore (1:30)

B. Structure

- Spherical roller bearings are non-separable, self-aligning bearings designed to support heavy and combined loads. Single-row spherical roller bearings feature one row of spherical rollers, a spherical raceway in the outer ring, and a single raceway in the inner ring, while double-row spherical roller bearings incorporate two rows of spherical rollers, a spherical raceway in the outer ring, and two raceways in the inner ring.
- These bearings are manufactured with either a cylindrical bore for direct mounting on the shaft or a tapered bore with a 1:12 taper (K designation) for mounting on adapter or withdrawal sleeves. Bearings of the 240 and 241 series are produced with a tapered bore of 1:30 (K30) and are mounted on sleeves of the corresponding taper.
- A key feature of most spherical roller bearings is a lubrication groove with three lubrication holes in the outer ring, commonly identified by the W33 designation.

C. Cages

- Cages stamped from steel sheet are the most commonly used in spherical roller bearings, particularly in smaller bearing sizes. Larger bearings are typically equipped with solid steel or brass cages. In addition, special versions of spherical roller bearings are available with cages made of glass-fiber-reinforced polyamide.

D. Features

- Spherical roller bearings are a specialized type of self-aligning bearing in which balls are replaced by spherical rollers. They retain all the advantages of self-aligning ball bearings while offering additional features that distinguish them from other bearing types. Due to the geometry of the rolling elements and the large contact area between the rollers and raceways, these bearings exhibit a very high load-carrying capacity—typically two to three times greater than that of self-aligning ball bearings.
- The inclined orientation of the spherical rollers relative to the bearing axis enables the bearing to accommodate substantial axial loads in both directions while simultaneously supporting radial loads. This design also provides excellent resistance to misalignment and shaft deflection. Under normal operating conditions with a rotating inner ring, spherical roller bearings can compensate for angular misalignment of up to 0.5° from the central position, and up to 2° under lighter loads, provided the surrounding design permits it. When the outer ring rotates, the permissible angular displacement is reduced.
- Standard spherical roller bearings are heat-stabilized for operation at temperatures above 120 °C. For smaller bearing sizes, the maximum operating temperature is typically around 150 °C, while larger bearings can operate at temperatures up to approximately 200 °C. Spherical roller bearings equipped with solid polyamide cages are suitable for continuous operation at temperatures not exceeding 100 °C.

E. Mounting on sleeves

- Spherical roller bearings, like self-aligning ball bearings, can be mounted on the shaft in two ways: directly on the shaft or with the help of an adapter sleeve (H). Sleeves generally facilitate bearing mounting and dismantling and, in many cases, simplify the bearing arrangement. When bearings are mounted using sleeves, the requirements for shaft manufacturing accuracy are lower than in cases of direct mounting on the shaft.
- To be mounted with an adapter sleeve, spherical roller bearings must have a tapered bore, indicated by the suffix K in the bearing designation. The standard taper of the tapered bore is 1:12; only bearings of the 240 and 241 series have a taper of 1:30, designated by K30.
- Adapter sleeves are widely used because they allow bearings to be mounted on both smooth and stepped shafts. Their mounting and dismantling are simple, and they do not require additional axial locating elements on the shaft. An important advantage of adapter sleeve arrangements is improved operational safety: in the event of bearing damage, the shaft is generally better protected compared to direct mounting solutions.

F. Comparison between self-aligning ball bearings

Parameters/ Bearing type	2210	22210	2310	22310
Basic dynamic load [kN]	33.8	84.5	63.7	176
Rotational Speed (grease) [r/min]	6300	5000	5300	3400

- The table above compares the capabilities of both types of self-aligning bearings. While their rotational characteristics are similar, the load capacity of spherical roller bearings is nearly three times that of self-aligning ball bearings. The geometry of the rolling elements and the angular orientation of the spherical rollers relative to the shaft axis enable these bearings to support substantial axial loads in both directions.
- Although self-aligning ball bearings can also carry axial loads in both directions, their capacity is significantly lower. Therefore, when there is any uncertainty about whether a planned self-aligning ball bearing will meet the design requirements, it is advisable to use a properly dimensioned spherical roller bearing.

1.1 SINGLE-ROW AND DOUBLE-ROW SPHERICAL ROLLER BEARINGS

20-50 mm
Z&S BEARINGS PRODUCTION

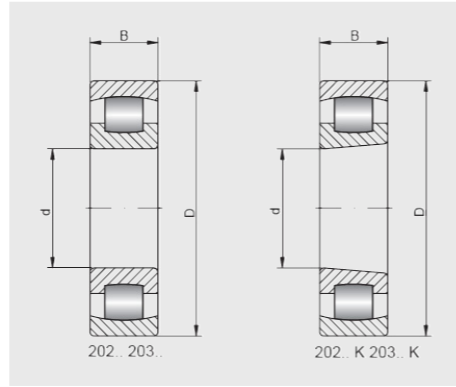

Shaft (mm)	Bearing No.	Series		Sleeve no. H.	Dimensions [mm]		
		SD	SB		d	D	B
20	20204 C	2	0	-	20	47	14
	20304 C	3	0	-	20	52	15
	21304 C	3	0	-	20	52	15
25	20205 C	2	0	-	25	52	15
	20205 KC	2	0	H205	25	52	15
	22205 CW33	2	2	-	25	52	18
	22205 KCW33	2	2	H305	25	52	18
	20305 C	3	0	-	25	62	17
30	21305 CW33	3	0	-	25	62	17
	20206 C	2	0	-	30	62	16
	20206 KC	2	0	H206	30	62	16
	22206 CW33	2	2	-	30	62	20
	22206 KCW33	2	2	H306	30	62	20
	20306 C	3	0	-	30	72	19
35	21306 CW33	3	0	-	30	72	19
	21306 KCW33	3	0	H306	30	72	19
	20207 C	2	0	-	35	72	17
	20207 KC	2	0	H207	35	72	17
	22207 CW33	2	2	-	35	72	23
	22207 KCW33	2	2	H307	35	72	23
	20307 C	3	0	-	35	80	21
	21307 CW33	3	0	-	35	80	21
40	21307 KCW33	3	0	H307	35	80	21
	22307 CW33	3	2	-	35	80	31
	22307 KCW33	3	2	H2307	35	80	31
	20208 C	2	0	-	40	80	18
	20208 KC	2	0	H208	40	80	18
	22208 CW33	2	2	-	40	80	23
	22208 KCW33	2	2	H308	40	80	23
	20308 C	3	0	-	40	90	23
	21308 CW33	3	0	-	40	90	23
	21308 KCW33	3	0	H308	40	90	23
45	22308 CW33	3	2	-	40	90	33
	22308 KCW33	3	2	H2308	40	90	33
	20209 C	2	0	-	45	85	19
	20209 KC	2	0	H209	45	85	19
	22209 CW33	2	2	-	45	85	23
	22209 KCW33	2	2	H309	45	85	23
	20309 C	3	0	-	45	100	25
	21309 CW33	3	0	-	45	100	25
	21309 KCW33	3	0	H309	45	100	25
	22309 CW33	3	2	-	45	100	36
50	22309 KCW33	3	2	H2309	45	100	36
	20210 C	2	0	-	50	90	20
	20210 KC	2	0	H210	50	90	20
	22210 CW33	2	2	-	50	90	23
22210 KCW33	2	2	H310	50	90	23	

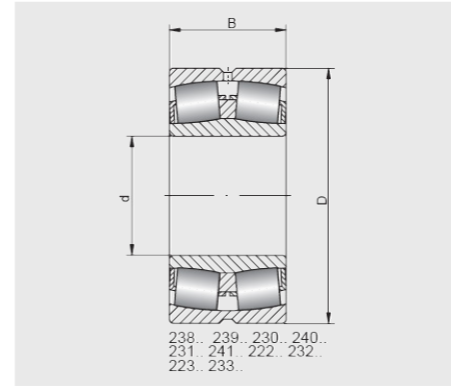

Basic makes	
-	M
✓	✓
TV	C3
✓	✓
C4	
✓	

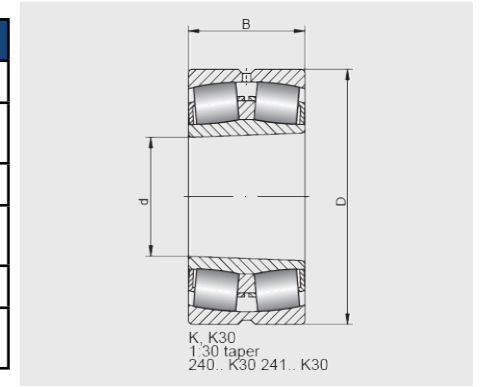

Weight (kg)	Basic load ratings (kN)		Limiting speed (rpm)		Bearing No.
	dyn. C	stat. C0	grease	oil	
0,114	20,4	19,3	5500	7250	20204 C
0,152	27	24,5	5000	6750	20304 C
0,16	34,4	33,6	7000	9500	21304 C
0,134	24	25	5000	6500	20205 C
0,145	24	25	5000	6500	20205 KC
0,18	43,1	44	8500	11000	22205 CW33
0,163	43,1	44	8500	11000	22205 KCW33
0,243	36	34,5	4500	5750	20305 C
0,25	41,4	41,5	6700	8500	21305 CW33
0,207	27,5	28,5	4000	5500	20206 C
0,228	27,5	28,5	4000	5500	20206 KC
0,28	48,9	52	7500	9500	22206 CW33
0,26	48,9	52	7500	9500	22206 KCW33
0,37	49	49	3750	4750	20306 C
0,38	55,2	61	6000	7500	21306 CW33
0,38	55,2	61	6000	7500	21306 KCW33
0,335	40,5	43	3500	4750	20207 C
0,301	40,5	43	3500	4750	20207 KC
0,43	67,3	73,5	6300	8000	22207 CW33
0,405	67,3	73,5	6300	8000	22207 KCW33
0,493	58,5	61	3250	4500	20307 C
0,51	65,6	72	5300	6700	21307 CW33
0,502	65,6	72	5300	6700	21307 KCW33
0,75	105	107	5100	6700	22307 CW33
0,733	105	107	5100	6700	22307 KCW33
0,386	49	53	3250	4250	20208 C
0,389	49	53	3250	4250	20208 KC
0,52	73,6	81,5	6000	7500	22208 CW33
0,487	73,6	81,5	6000	7500	22208 KCW33
0,671	76,5	81,5	3000	4000	20308 C
0,71	82,8	98	4500	5600	21308 CW33
0,706	82,8	98	4500	5600	21308 KCW33
1	115	122	4500	5600	22308 CW33
0,984	115	122	4500	5600	22308 KCW33
0,441	52	57	3000	4000	20209 C
0,483	52	57	3000	4000	20209 KC
0,56	77,1	88	5300	6700	22209 CW33
0,57	77,1	88	5300	6700	22209 KCW33
0,914	86,5	95	2750	3500	20309 C
0,95	101	114	4300	5300	21309 CW33
0,947	101	114	4300	5300	21309 KCW33
1,35	138	160	3800	4800	22309 CW33
1,36	138	160	3800	4800	22309 KCW33
0,499	58,5	68	2750	3500	20210 C
0,49	58,5	68	2750	3500	20210 KC
0,6	84,5	100	5000	6300	22210 CW33
0,582	84,5	100	5000	6300	22210 KCW33

1.1 SINGLE-ROW AND DOUBLE-ROW SPHERICAL ROLLER BEARINGS

50-75 mm

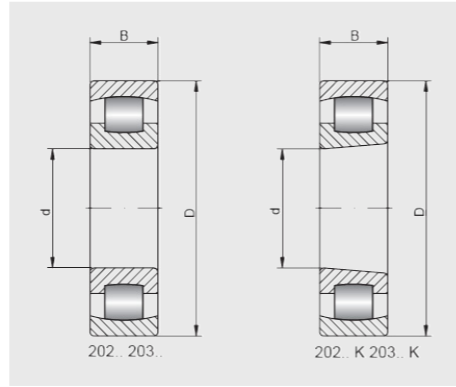

Shaft (mm)	Bearing No.	Series		Sleeve no. H.	Dimensions [mm]			
		SD	SB		d	D	B	
50 cont.	20310 C	3	0	-	50	110	27	
	21310 CW33	3	0	-	50	110	27	
	21310 KCW33	3	0	H310	50	110	27	
	22310 CW33	3	2	-	50	110	40	
55	22310 KCW33	3	2	H2310	50	110	40	
	20211 C	2	0	-	55	100	21	
	20211 KC	2	0	H211	55	100	21	
	22211 CW33	2	2	-	55	100	25	
	22211 KCW33	2	2	H311	55	100	25	
	20311 C	3	0	-	55	120	29	
	20311 KC	3	0	H311	55	120	29	
	21311 CW33	3	0	-	55	120	29	
	21311 KCW33	3	0	H311	55	120	29	
	22311 CW33	3	2	-	55	120	43	
	22311 KCW33	3	2	H2311	55	120	43	
	60	20212 C	2	0	-	60	110	22
20212 KC		2	0	H212	60	110	22	
22212 CW33		2	2	-	60	110	28	
22212 KCW33		2	2	H312	60	110	31	
20312 C		3	0	-	60	130	31	
20312 KC		3	0	H312	60	130	31	
21312 CW33		3	0	-	60	130	31	
21312 KCW33		3	0	H312	60	130	31	
22312 CW33		3	2	-	60	130	46	
22312 KCW33		3	2	H2312	60	130	46	
65		20213 C	2	0	-	65	120	23
		20213 KC	2	0	H213	65	120	23
	22213 CW33	2	2	-	65	120	31	
	22213 KCW33	2	2	H313	65	120	31	
	20313 C	3	0	-	65	140	33	
	20313 KC	3	0	H313	65	140	33	
	21313 CW33	3	0	-	65	140	33	
	21313 KCW33	3	0	H313	65	140	33	
	22313 CW33	3	2	-	65	140	48	
	22313 KCW33	3	2	H2313	65	140	48	
	70	20214 C	2	0	-	70	125	24
		22214 CW33	2	2	-	70	125	31
22214 KCW33		2	2	H314	70	125	31	
20314 C		3	0	-	70	150	35	
21314 CW33		3	0	-	70	150	35	
21314 KCW33		3	0	H314	70	150	35	
22314 CW33		3	2	-	70	150	51	
22314 KCW33		3	2	H2314	70	150	51	
75	20215 C	2	0	-	75	130	25	
	20215 KC	2	0	H215	75	130	25	
	22215 CW33	2	2	-	75	130	31	
	22215 KCW33	2	2	H315	75	130	31	

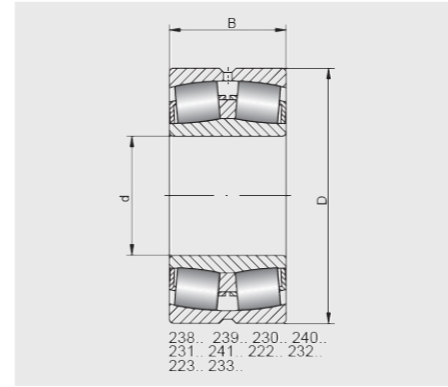

Basic makes	
-	M
✓	✓
TV	C3
✓	✓
C4	
✓	

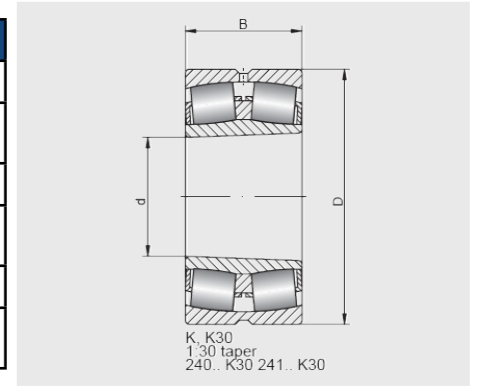

Weight (kg)	Basic load ratings (kN)		Limiting speed (rpm)		Bearing No.
	dyn. C	stat. C0	grease	oil	
1,17	108	118	2500	3250	20310 C
1,2	120	140	3600	4800	21310 CW33
1,21	120	140	3600	4800	21310 KCW33
1,85	176	200	3400	4300	22310 CW33
1,7	176	200	3400	4300	22310 KCW33
0,653	73,5	85	2500	3250	20211 C
0,78	73,5	85	2500	3250	20211 KC
0,82	99,5	118	4500	5600	22211 CW33
0,8	99,5	118	4500	5600	22211 KCW33
1,53	120	137	2250	3000	20311 C
1,64	120	137	2250	3000	20311 KC
1,6	138	163	3400	4300	21311 CW33
1,55	138	163	3400	4300	21311 KCW33
2,35	199	232	3200	4000	22311 CW33
2,02	199	232	3200	4000	22311 KCW33
0,836	85	100	2500	3250	20212 C
0,93	85	100	2500	3250	20212 KC
1,1	122	146	4000	5000	22212 CW33
1	122	146	4000	5000	22212 KCW33
1,92	146	170	2000	2750	20312 C
2	146	170	2000	2750	20312 KC
1,95	161	200	3000	3800	21312 CW33
1,93	161	200	3000	3800	21312 KCW33
2,9	235	280	3000	3800	22312 CW33
2,8	235	280	3000	3800	22312 KCW33
1,08	95	116	2250	3000	20213 C
1,19	95	116	2250	3000	20213 KC
1,45	176	216	3800	4800	22213 CW33
1,27	176	216	3800	4800	22213 KCW33
2,18	170	196	2000	2750	20313 C
2,53	170	196	2000	2750	20313 KC
2,45	184	240	2800	3600	21313 CW33
2,42	184	240	2800	3600	21313 KCW33
3,55	253	300	2600	3400	22313 CW33
3,57	253	300	2600	3400	22313 KCW33
1,17	106	134	2000	2750	20214 C
1,55	148	186	3600	4500	22214 CW33
1,46	148	186	3600	4500	22214 KCW33
3,15	183	216	2000	2500	20314 C
3	207	260	2600	3400	21314 CW33
2,95	207	260	2600	3400	21314 KCW33
4,3	311	380	2400	3200	22314 CW33
4,25	311	380	2400	3200	22314 KCW33
1,28	112	143	2000	2750	20215 C
1,4	112	143	2000	2750	20215 KC
1,65	158	208	3400	4300	22215 CW33
1,65	158	208	3400	4300	22215 KCW33

1.1 SINGLE-ROW AND DOUBLE-ROW SPHERICAL ROLLER BEARINGS

75-100 mm
Z&S BEARINGS PRODUCTION

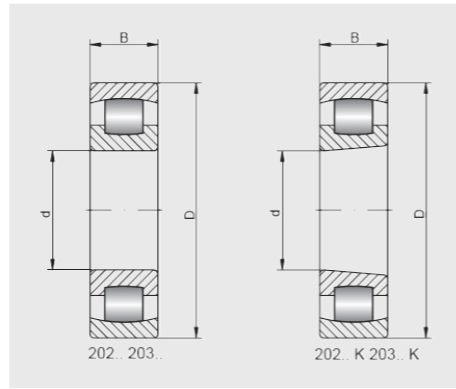

Shaft (mm)	Bearing No.	Series		Sleeve no.	Dimensions [mm]			
		SD	SB	H.	d	D	B	
75 cont.	20315 C	3	0	-	75	160	37	
	21315 CW33	3	0	-	75	160	37	
	21315 KCW33	3	0	H315	75	160	37	
	22315 CW33	3	2	-	75	160	55	
80	22315 KCW33	3	2	H2315	75	160	55	
	20216 C	2	0	-	80	140	26	
	20216 KC	2	0	H216	80	140	26	
	22216 CW33	2	2	-	80	140	33	
	22216 KCW33	2	2	H316	80	140	33	
	20316 C	3	0	-	80	170	39	
	21316 CW33	3	0	-	80	170	39	
	21316 KCW33	3	0	H316	80	170	39	
	22316 CW33	3	2	-	80	170	58	
	22316 KCW33	3	2	H2316	80	170	58	
	85	20217 C	2	0	-	85	150	28
		20217 KC	2	0	H217	85	150	28
22217 CW33		2	2	-	85	150	36	
22217 KCW33		2	2	H317	85	150	36	
20317 C		3	0	-	85	180	41	
21317 CW33		3	0	-	85	180	41	
21317 KCW33		3	0	H317	85	180	41	
22317 CW33		3	2	-	85	180	60	
22317 KCW33		3	2	H2317	85	180	60	
90		20218 C	2	0	-	90	160	30
		20218 KC	2	0	H218	90	160	30
		22218 CW33	2	2	-	90	160	40
	22218 KCW33	2	2	H318	90	160	40	
	23218 CW33	2	3	-	90	160	52.4	
	23218 KCW33	2	3	H2318	90	160	52.4	
	20318 C	3	0	-	90	190	43	
	20318 KC	3	0	H318	90	190	43	
	21318 CW33	3	0	-	90	190	43	
	21318 KCW33	3	0	H318	90	190	43	
	22318 CW33	3	2	-	90	190	64	
	22318 KCW33	3	2	H2318	90	190	64	
95	20219 C	2	0	-	95	170	32	
	22219 CW33	2	2	-	95	170	43	
	22219 KCW33	2	2	H319	95	170	43	
	20319 C	3	0	-	95	200	45	
	21319 CW33	3	0	-	95	200	45	
	21319 KCW33	3	0	H319	95	200	45	
	22319 CW33	3	2	-	95	200	67	
	22319 KCW33	3	2	H2319	95	200	67	
100	23120 CW33	1	3	-	100	165	52	
	23120 KCW33	1	3	H3120	100	165	52	
	20220 C	2	0	-	100	180	34	
	20220 KC	2	0	H220	100	180	34	

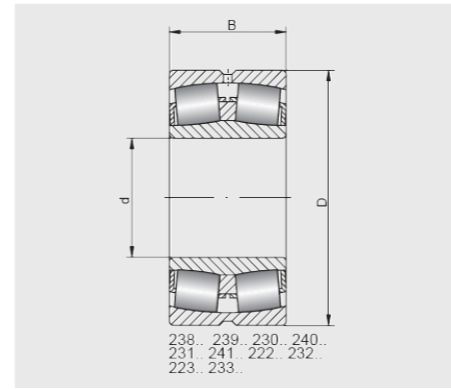

Basic makes	
-	M
✓	✓
TV	C3
✓	✓
C4	
✓	

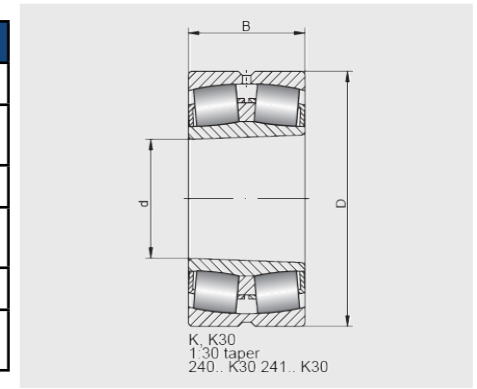

Weight (kg)	Basic load ratings (kN)		Limiting speed (rpm)		Bearing No.
	dyn. C	stat. C0	grease	oil	
3,76	216	255	1750	2250	20315 C
3,55	235	300	2400	3200	21315 CW33
3,55	235	300	2400	3200	21315 KCW33
5,25	345	430	2200	3000	22315 CW33
5,01	345	430	2200	3000	22315 KCW33
1,58	125	163	2000	2500	20216 C
1,72	125	163	2000	2500	20216 KC
2,1	207	270	3200	4000	22216 CW33
1,97	176	228	3200	4000	22216 KCW33
4,58	245	285	1500	2000	20316 C
4,2	258	335	2200	3000	21316 CW33
4,23	258	335	2200	3000	21316 KCW33
6,2	374	455	2000	2800	22316 CW33
5,95	374	455	2000	2800	22316 KCW33
2,22	156	200	1750	2500	20217 C
2,14	156	200	1750	2500	20217 KC
2,55	210	270	3000	3800	22217 CW33
2,49	210	270	3000	3800	22217 KCW33
5,25	270	320	1500	2000	20317 C
5	293	375	2000	2800	21317 CW33
4,93	293	375	2000	2800	21317 KCW33
7,25	420	520	1900	2600	22317 CW33
6,84	420	520	1900	2600	22317 KCW33
2,72	173	220	1500	2000	20218 C
2,63	173	220	1500	2000	20218 KC
3,4	253	340	2600	3400	22218 CW33
3,2	253	340	2600	3400	22218 KCW33
4,6	311	440	1900	2600	23218 CW33
4,2	311	440	1900	2600	23218 KCW33
6,25	300	360	1500	2000	20318 C
6,03	300	360	1500	2000	20318 KC
5,8	322	425	1900	2600	21318 CW33
5,74	322	425	1900	2600	21318 KCW33
8,6	477	610	1800	2400	22318 CW33
8,08	477	610	1800	2400	22318 KCW33
3,19	208	265	1500	2000	20219 C
4	282	375	2400	3200	22219 CW33
3,89	282	375	2400	3200	22219 KCW33
7,29	335	400	1500	1750	20319 C
7,15	351	480	1800	2400	21319 CW33
6,63	351	480	1800	2400	21319 KCW33
10	518	670	1800	2400	22319 CW33
9,21	518	670	1800	2400	22319 KCW33
4,4	322	490	2000	2800	23120 CW33
4,2	322	490	2000	2800	23120 KCW33
3,96	224	290	1500	2000	20220 C
3,81	224	290	1500	2000	20220 KC

1.1 SINGLE-ROW AND DOUBLE-ROW SPHERICAL ROLLER BEARINGS

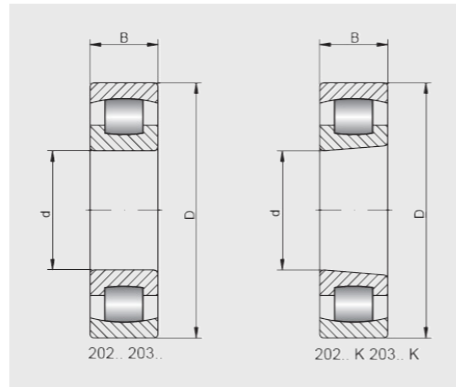

100-120 mm



Shaft (mm)	Bearing No.	Series		Sleeve no. H.	Dimensions [mm]			
		SD	SB		d	D	B	
100 cont.	22220 CW33	2	2	-	100	180	46	
	22220 KCW33	2	2	H320	100	180	46	
	23220 CW33	2	3	-	100	180	60.3	
	23220 KCW33	2	3	H2320	100	180	60.3	
	20320 C	3	0	-	100	215	47	
	20320 KC	3	0	H320	100	215	47	
	21320 CW33	3	0	-	100	215	47	
	21320 KCW33	3	0	H320	100	215	47	
	22320 CW33	3	2	-	100	215	73	
	22320 KCW33	3	2	H2320	100	215	73	
	23320 CW33	3	3	-	100	215	82,6	
	105	20221 C	2	0	-	105	190	36
110	23022 CW33	0	3	-	110	170	45	
	23022 KCW33	0	3	H3022	110	170	45	
	23122 CW33	1	3	-	110	180	56	
	23122 KCW33	1	3	H3122	110	180	56	
	24122 CW33	1	4	-	110	180	69	
	24122 K30CW33	1	4	-	110	180	69	
	20222 C	2	0	-	110	200	38	
	20222 KC	2	0	H222	110	200	38	
	22222 CW33	2	2	-	110	200	53	
	22222 KCW33	2	2	H322	110	200	53	
	23222 CW33	2	3	-	110	200	70	
	23222 KCW33	2	3	H2322	110	200	70	
	20322 C	3	0	-	110	240	50	
	21322 CW33	3	0	-	110	240	50	
	21322 KCW33	3	0	H322	110	240	50	
	22322 CW33	3	2	-	110	240	80	
	22322 KCW33	3	2	H2322	110	240	80	
	23322 CW33	3	3	-	110	240	92	
	120	23024 CW33	0	3	-	120	180	46
		23024 KCW33	0	3	H3024	120	180	46
		24024 CW33	0	4	-	120	180	60
		24024 K30CW33	0	4	-	120	180	60
		23124 CW33	1	3	-	120	200	62
		23124 KCW33	1	3	H3124	120	200	62
24124 CW33		1	4	-	120	200	80	
24124 K30CW33		1	4	-	120	200	80	
20224 C		2	0	-	120	215	40	
20224 KC		2	0	H3024	120	215	40	
22224 CW33		2	2	-	120	215	58	
22224 KCW33		2	2	H3124	120	215	58	
23224 CW33		2	3	-	120	215	76	
23224 KCW33		2	3	H2324	120	215	76	
20324 C		3	0	-	120	260	55	
22324 CW33		3	2	-	120	260	86	
22324 KCW33		3	2	H2324	120	260	86	

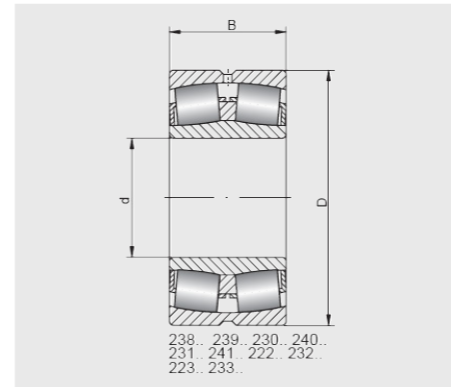

Basic makes	
-	M
✓	✓
TV	C3
✓	✓
C4	
✓	

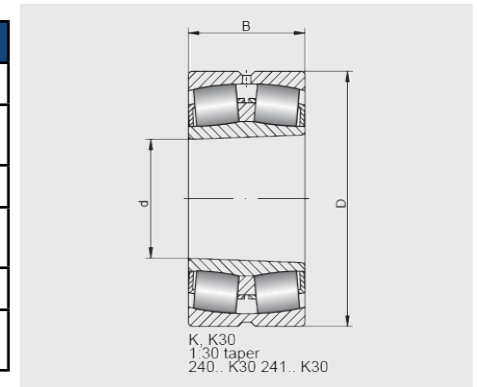

Weight (kg)	Basic load ratings (kN)		Limiting speed (rpm)		Bearing No.
	dyn. C	stat. C0	grease	oil	
4,85	311	415	2200	3000	22220 CW33
4,72	311	415	2200	3000	22220 KCW33
6,7	414	600	1700	2200	23220 CW33
6,2	414	600	1700	2200	23220 KCW33
8,69	365	440	1250	1750	20320 C
8,46	365	440	1250	1750	20320 KC
8,8	385	530	1700	2200	21320 CW33
8,19	385	530	1700	2200	21320 KCW33
13	610	800	1700	2200	22320 CW33
11,7	610	800	1700	2200	22320 KCW33
15,3	680	900	1650	2150	23320 CW33
4,74	245	315	1500	1750	20221 C
3,75	267	440	2200	3000	23022 CW33
3,87	286	478	2200	3000	23022 KCW33
5,55	374	585	1900	2600	23122 CW33
5,13	374	585	1900	2600	23122 KCW33
6,85	460	750	1000	1400	24122 CW33
6,85	460	750	1000	1400	24122 K30CW33
5,53	285	375	1250	1750	20222 C
5,34	285	375	1250	1750	20222 KC
7	408	560	2000	2800	22222 CW33
7,1	408	560	2000	2800	22222 KCW33
9,7	518	765	1600	2000	23222 CW33
9,1	518	765	1600	2000	23222 KCW33
11,6	430	520	1250	1500	20322 C
12	460	630	1600	2000	21322 CW33
11,1	460	630	1600	2000	21322 KCW33
17,5	725	965	1600	2000	22322 CW33
17,4	725	965	1600	2000	22322 KCW33
21,1	830	1080	1550	1950	23322 CW33
4,2	305	510	2000	2800	23024 CW33
4,22	305	510	2000	2800	23024 KCW33
5,4	374	670	1600	2000	24024 CW33
4,96	397	709	1700	2300	24024 K30CW33
7,8	449	695	1800	2400	23124 CW33
7,3	449	695	1800	2400	23124 KCW33
10	575	950	900	1200	24124 CW33
10	575	950	900	1200	24124 K30CW33
6,6	305	415	1250	1750	20224 C
6,41	305	415	1250	1750	20224 KC
8,7	466	670	1900	2600	22224 CW33
8,72	466	670	1900	2600	22224 KCW33
12	610	930	1500	1900	23224 CW33
11	610	930	1500	1900	23224 KCW33
15,2	490	630	1000	1500	20324 C
22	845	1120	1400	1800	22324 CW33
21	845	1120	1400	1800	22324 KCW33

1.1 SINGLE-ROW AND DOUBLE-ROW SPHERICAL ROLLER BEARINGS

120-150 mm

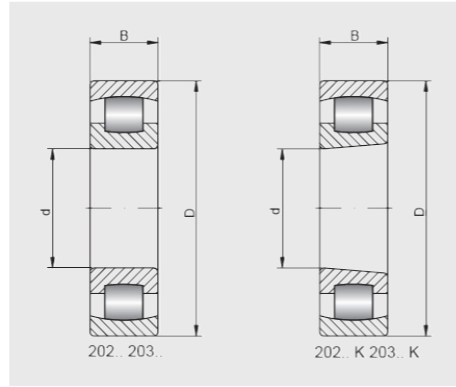

Shaft (mm)	Bearing No.	Series		Sleeve no. H.	Dimensions [mm]		
		SD	SB		d	D	B
120 cont.	23324 CW33	3	3	-	120	260	106
130	23026 CW33	0	3	-	130	200	52
	23026 KCW33	0	3	H3026	130	200	52
	24026 CW33	0	4	-	130	200	69
	24026 K30CW33	0	4	-	130	200	69
	23126 CW33	1	3	-	130	210	64
	23126 KCW33	1	3	H3126	130	210	64
	24126 CW33	1	4	-	130	210	80
	24126 K30CW33	1	4	-	130	210	80
	20226 C	2	0	-	130	230	40
	20226 KC	2	0	H3026	130	230	40
	22226 CW33	2	2	-	130	230	64
	22226 KCW33	2	2	H3126	130	230	64
	23226 CW33	2	3	-	130	230	80
	23226 KCW33	2	3	H2326	130	230	80
	20326 C	3	0	-	130	280	58
	22326 CW33	3	2	-	130	280	93
	22326 KCW33	3	2	H2326	130	280	93
	23326 CW33	3	3	-	130	280	112
140	23028 CW33	0	3	-	140	210	53
	23028 KCW33	0	3	H3028	140	210	53
	24028 CW33	0	4	-	140	210	69
	24028 K30CW33	0	4	-	140	210	69
	23128 CW33	1	3	-	140	225	68
	23128 KCW33	1	3	H3128	140	225	68
	24128 CW33	1	4	-	140	225	85
	24128 K30CW33	1	4	-	140	225	85
	20228 C	2	0	-	140	250	42
	20228 KC	2	0	H3028	140	250	42
	22228 CW33	2	2	-	140	250	68
	22228 KCW33	2	2	H3128	140	250	68
	23228 CW33	2	3	-	140	250	88
	23228 KCW33	2	3	H2328	140	250	88
	20328 C	3	0	-	140	300	62
	22328 CW33	3	2	-	140	300	102
	22328 KCW33	3	2	H2328	140	300	102
	23328 CW33	3	3	-	140	300	118
150	23930 CW33	9	3	-	150	210	45
	23930 KCW33	9	3	H3930	150	210	45
	23030 CW33	0	3	-	150	225	56
	23030 KCW33	0	3	H3030	150	225	56
	24030 CW33	0	4	-	150	225	75
	24030 K30CW33	0	4	-	150	225	75
	23130 CW33	1	3	-	150	250	80
	23130 KCW33	1	3	H3130	150	250	80
	24130 CW33	1	4	-	150	250	100
	24130 K30CW33	1	4	-	150	250	100

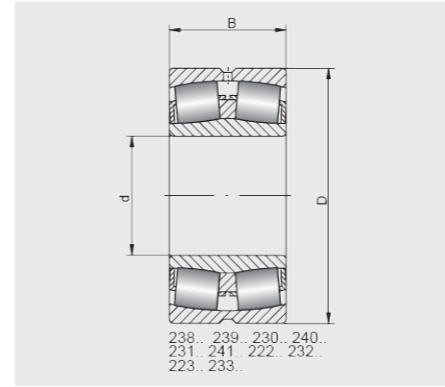

Basic makes	
-	M
✓	✓
TV	C3
✓	✓
C4	
✓	

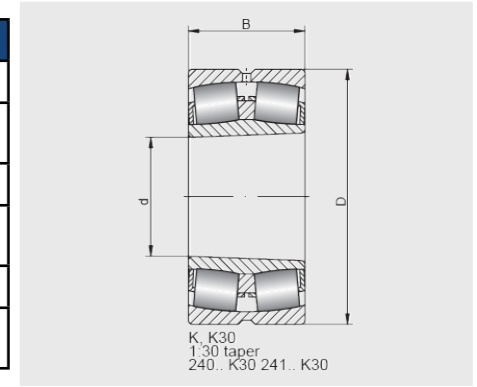

Weight (kg)	Basic load ratings (kN)		Limiting speed (rpm)		Bearing No.
	dyn. C	stat. C0	grease	oil	
28,9	1020	1430	1350	1750	23324 CW33
6,1	374	610	1900	2600	23026 CW33
5,6	374	610	1900	2600	23026 KCW33
7,95	374	670	1600	2000	24026 CW33
7,33	512	914	1600	2100	24026 K30CW33
8,55	489	780	1700	2200	23126 CW33
8,1	489	780	1700	2200	23126 KCW33
11	587	1000	900	1200	24126 CW33
11	587	1000	900	1200	24126 K30CW33
7,31	335	450	1250	1500	20226 C
7,19	335	450	1250	1500	20226 KC
11	546	800	1800	2400	22226 CW33
10,4	546	800	1800	2400	22226 KCW33
14	690	1060	1300	1700	23226 CW33
13	690	1060	1300	1700	23226 KCW33
18,4	550	720	1000	1500	20326 C
28,5	978	1320	1300	1700	22326 CW33
26,7	978	1320	1300	1700	22326 KCW33
35,3	1160	1600	1250	1650	23326 CW33
6,55	397	680	1800	2400	23028 CW33
6	397	680	1800	2400	23028 KCW33
8,45	495	900	1400	1800	24028 CW33
8,5	495	900	1400	1800	24028 K30CW33
10,5	546	900	1600	2000	23128 CW33
9,8	546	900	1600	2000	23128 KCW33
13	673	1160	850	1100	24128 CW33
13	673	1160	850	1100	24128 K30CW33
9,09	390	530	1000	1500	20228 C
9	390	530	1000	1500	20228 KC
14	610	900	1700	2200	22228 CW33
13,5	610	900	1700	2200	22228 KCW33
18,5	799	1250	1200	1600	23228 CW33
17,7	799	1250	1200	1600	23228 KCW33
22,5	640	850	1000	1250	20328 C
34,5	1130	1560	1100	1500	22328 CW33
34	1130	1560	1100	1500	22328 KCW33
40,7	1270	1800	1050	1450	23328 CW33
4,97	334	622	1900	2550	23930 CW33
4,81	334	622	1900	2550	23930 KCW33
7,95	437	750	1700	2200	23030 CW33
7	437	750	1700	2200	23030 KCW33
10,5	564	1040	1300	1700	24030 CW33
10,5	564	1040	1300	1700	24030 K30CW33
16	725	1200	1400	1800	23130 CW33
15	725	1200	1400	1800	23130 KCW33
19,5	897	1530	800	1000	24130 CW33
19,5	897	1530	800	1000	24130 K30CW33

1.1 SINGLE-ROW AND DOUBLE-ROW SPHERICAL ROLLER BEARINGS

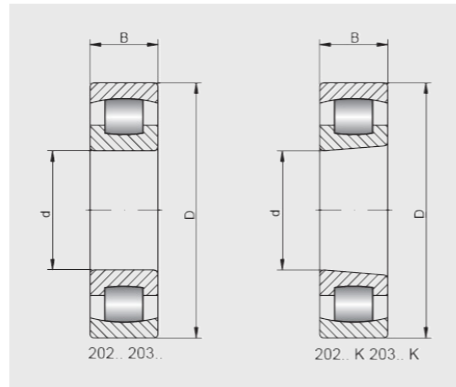

150-170 mm



Shaft (mm)	Bearing No.	Series		Sleeve no.	Dimensions [mm]		
		SD	SB	H.	d	D	B
150 cont.	20230 C	2	0	-	150	270	45
	20230 KC	2	0	H3030	150	270	45
	22230 CW33	2	2	-	150	270	73
	22230 KCW33	2	2	H3130	150	270	73
	23230 CW33	2	3	-	150	270	96
	23230 KCW33	2	3	H2330	150	270	96
	20330 C	3	0	-	150	320	65
	22330 CW33	3	2	-	150	320	108
	22330 KCW33	3	2	H2330	150	320	108
	23330 CW33	3	3	-	150	320	128
	23932 CW33	9	3	-	160	220	45
	23932 KCW33	9	3	H3932	160	220	45
160	23032 CW33	0	3	-	160	240	60
	23032 KCW33	0	3	H3032	160	240	60
	24032 CW33	0	4	-	160	240	80
	24032 K30CW33	0	4	-	160	240	80
	23132 CW33	1	3	-	160	270	86
	23132 KCW33	1	3	H3132	160	270	86
	24132 CW33	1	4	-	160	270	109
	24132 K30CW33	1	4	-	160	270	109
	20232 C	2	0	-	160	290	48
	20232 KC	2	0	H3032	160	290	48
	22232 CW33	2	2	-	160	290	80
	22232 KCW33	2	2	H3132	160	290	80
	23232 CW33	2	3	-	160	290	104
	23232 KCW33	2	3	H2332	160	290	104
	22332 CW33	3	2	-	160	340	114
	22332 KCW33	3	2	H2332	160	340	114
	23332 CW33	3	3	-	160	340	136
	23934 CW33	9	3	-	170	230	45
	23934 KCW33	9	3	H3934	170	230	45
	23034 CW33	0	3	-	170	260	67
	23034 KCW33	0	3	H3034	170	260	67
	24034 CW33	0	4	-	170	260	90
	24034 K30CW33	0	4	-	170	260	90
	23134 CW33	1	3	-	170	280	88
	23134 KCW33	1	3	H3134	170	280	88
	24134 CW33	1	4	-	170	280	109
	24134 K30CW33	1	4	-	170	280	109
	20234 C	2	0	-	170	310	52
	22234 CW33	2	2	-	170	310	86
	22234 KCW33	2	2	H3134	170	310	86
	23234 CW33	2	3	-	170	310	110
	23234 KCW33	2	3	H2334	170	310	110
22334 CW33	3	2	-	170	360	120	
22334 KCW33	3	2	H2334	170	360	120	

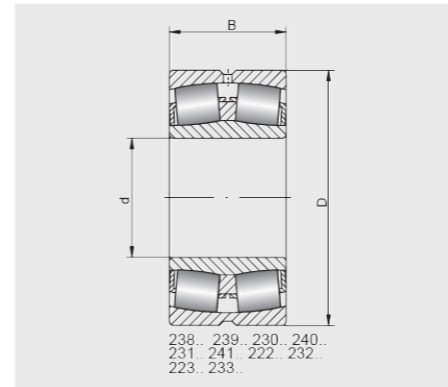

Basic makes	
-	M
✓	✓
TV	C3
✓	✓
C4	
✓	

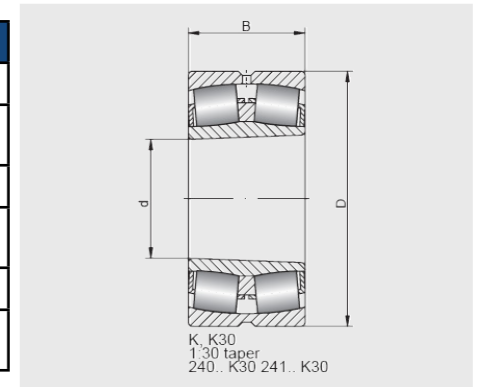

Weight (kg)	Basic load ratings (kN)		Limiting speed (rpm)		Bearing No.
	dyn. C	stat. C0	grease	oil	
11,7	430	610	1000	1250	20230 C
11,5	430	610	1000	1250	20230 KC
18	736	1080	1600	2000	22230 CW33
17	736	1080	1600	2000	22230 KCW33
24	937	1460	1100	1500	23230 CW33
22	937	1460	1100	1500	23230 KCW33
26,9	720	950	1000	1250	20330 C
41,5	1270	1760	1000	1400	22330 CW33
40,6	1270	1760	1000	1400	22330 KCW33
49,8	1500	2120	950	1350	23330 CW33
5,25	341	649	1850	2450	23932 CW33
5,08	341	649	1850	2450	23932 KCW33
9,7	506	880	1700	2200	23032 CW33
8	506	880	1700	2200	23032 KCW33
13	656	1200	1100	1500	24032 CW33
13	656	1200	1100	1500	24032 K30CW33
20,5	845	1370	1300	1700	23132 CW33
19	845	1370	1300	1700	23132 KCW33
25	1040	1760	700	900	24132 CW33
25	1040	1760	700	900	24132 K30CW33
14,5	500	720	1000	1250	20232 C
14,3	500	720	1000	1250	20232 KC
22,5	863	1290	1500	1900	22232 CW33
22,5	863	1290	1500	1900	22232 KCW33
30	1070	1660	1000	1400	23232 CW33
28,9	1070	1660	1000	1400	23232 KCW33
50	1380	1960	950	1300	22332 CW33
50,5	1380	1960	950	1300	22332 KCW33
62,6	1660	2320	900	1250	23332 CW33
5,53	353	691	1800	2350	23934 CW33
5,35	353	691	1800	2350	23934 KCW33
13	621	1060	1600	2000	23034 CW33
12,1	621	1060	1600	2000	23034 KCW33
17,5	799	1460	1000	1400	24034 CW33
17,5	799	1460	1000	1400	24034 K30CW33
21,5	897	1500	1200	1600	23134 CW33
20,6	897	1500	1200	1600	23134 KCW33
26,5	1070	1860	670	850	24134 CW33
26,5	1070	1860	670	850	24134 K30CW33
17,9	570	830	1000	1250	20234 C
28,5	978	1460	1300	1700	22234 CW33
26,3	978	1460	1300	1700	22234 KCW33
36,5	1220	1930	950	1300	23234 CW33
34,2	1220	1930	950	1300	23234 KCW33
58,5	1540	2160	950	1300	22334 CW33
58,2	1540	2160	950	1300	22334 KCW33

1.1 SINGLE-ROW AND DOUBLE-ROW SPHERICAL ROLLER BEARINGS

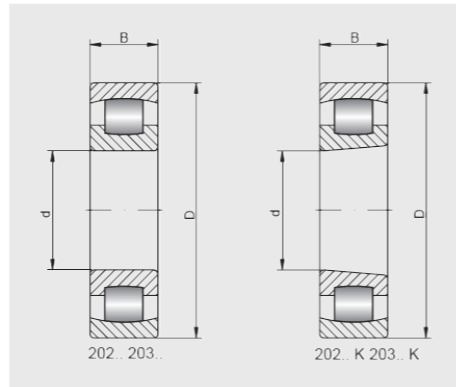

180-200 mm



Shaft (mm)	Bearing No.	Series		Sleeve no. H.	Dimensions [mm]			
		SD	SB		d	D	B	
180	23936 CW33	9	3	-	180	250	52	
	23936 KCW33	9	3	H3936	180	250	52	
	23036 CW33	0	3	-	180	280	74	
	23036 KCW33	0	3	H3036	180	280	74	
	24036 CW33	0	4	-	180	280	100	
	24036 K30CW33	0	4	-	180	280	100	
	23136 CW33	1	3	-	180	300	96	
	23136 KCW33	1	3	H3136	180	300	96	
	24136 CW33	1	4	-	180	300	118	
	24136 K30CW33	1	4	-	180	300	118	
	20236 C	2	0	-	180	320	52	
	22236 CW33	2	2	-	180	320	86	
	22236 KCW33	2	2	H3136	180	320	86	
	23236 CW33	2	3	-	180	320	112	
	23236 KCW33	2	3	H2336	180	320	112	
	22336 CW33	3	2	-	180	380	126	
	22336 KCW33	3	2	H2336	180	380	126	
	190	23938 CW33	9	3	-	190	260	52
		23938 KCW33	9	3	H3938	190	260	52
		23038 CW33	0	3	-	190	290	75
23038 KCW33		0	3	H3038	190	290	75	
24038 CW33		0	4	-	190	290	100	
24038 K30CW33		0	4	-	190	290	100	
23138 CW33		1	3	-	190	320	104	
23138 KCW33		1	3	H3138	190	320	104	
24138 CW33		1	4	-	190	320	128	
24138 K30CW33		1	4	-	190	320	128	
20238 C		2	0	-	190	340	55	
22238 CW33		2	2	-	190	340	92	
22238 KCW33		2	2	H3138	190	340	92	
23238 CW33		2	3	-	190	340	120	
23238 KCW33		2	3	H2338	190	340	120	
190 cont.	22338 CW33	3	2	-	190	400	132	
	22338 KCW33	3	2	H2338	190	400	132	
	23338 CW33	3	3	-	190	400	155	
	200	23940 CW33	9	3	-	200	280	60
		23940 KCW33	9	3	H3940	200	280	60
23040 CW33		0	3	-	200	310	82	
23040 KCW33		0	3	H3040	200	310	82	
24040 CW33		0	4	-	200	310	109	
24040 K30CW33		0	4	-	200	310	109	
23140 CW33		1	3	-	200	340	112	
23140 KCW33		1	3	H3140	200	340	112	
24140 CW33		1	4	-	200	340	140	
24140 K30CW33		1	4	-	200	340	140	
20240 C	2	0	-	200	360	58		

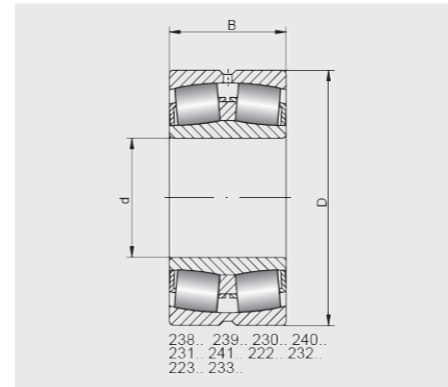

Basic makes	
-	M
✓	✓
TV	C3
✓	✓
C4	
✓	

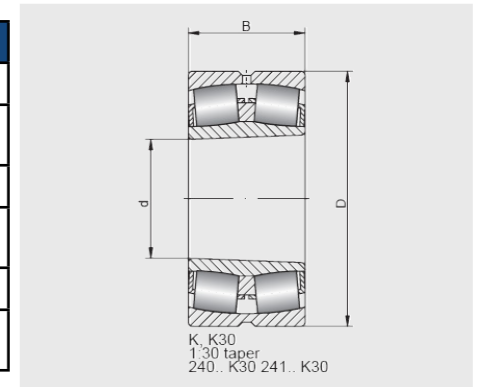

Weight (kg)	Basic load ratings (kN)		Limiting speed (rpm)		Bearing No.
	dyn. C	stat. C0	grease	oil	
8,2	431	830	1700	2200	23936 CW33
7,7	431	830	1700	2200	23936 KCW33
17	725	1250	1400	1800	23036 CW33
16,6	725	1250	1400	1800	23036 KCW33
23	937	1730	950	1300	24036 CW33
23	937	1730	950	1300	24036 K30CW33
27,5	1050	1760	1100	1500	23136 CW33
26,8	1050	1760	1100	1500	23136 KCW33
33,5	1220	2160	630	800	24136 CW33
33,5	1220	2160	630	800	24136 K30CW33
18,4	585	850	750	1000	20236 C
29,5	1010	1560	1300	1700	22236 CW33
28,5	1010	1560	1300	1700	22236 KCW33
39	1290	2120	900	1200	23236 CW33
38,6	1290	2120	900	1200	23236 KCW33
69	1730	2450	900	1200	22336 CW33
68,5	1730	2450	900	1200	22336 KCW33
8,4	414	800	1700	2200	23938 CW33
8,3	414	800	1700	2200	23938 KCW33
18	753	1340	1300	1700	23038 CW33
16,9	753	1340	1300	1700	23038 KCW33
24	978	1800	950	1300	24038 CW33
24	978	1800	950	1300	24038 K30CW33
34,5	1200	2080	1000	1400	23138 CW33
31,4	1200	2080	1000	1400	23138 KCW33
42	1400	2500	600	750	24138 CW33
42	1400	2500	600	750	24138 K30CW33
22,5	640	950	750	1000	20238 C
36,5	1110	1700	1200	1600	22238 CW33
37	1110	1700	1200	1600	22238 KCW33
47,5	1460	2400	850	1100	23238 CW33
47,5	1460	2400	850	1100	23238 KCW33
80	1870	2650	850	1100	22338 CW33
79,4	1870	2650	850	1100	22338 KCW33
97,1	2200	3200	800	1050	23338 CW33
11,5	546	1040	1600	2000	23940 CW33
12,3	546	1040	1600	2000	23940 KCW33
23	880	1530	1200	1600	23040 CW33
22,3	880	1530	1200	1600	23040 KCW33
30,5	1130	2120	900	1200	24040 CW33
30,5	1130	2120	900	1200	24040 K30CW33
42,5	1380	2360	950	1300	23140 CW33
41,6	1380	2360	950	1300	23140 KCW33
52	1580	2800	560	700	24140 CW33
52	1580	2800	560	700	24140 K30CW33
26,7	735	1080	750	1000	20240 C

1.1 SINGLE-ROW AND DOUBLE-ROW SPHERICAL ROLLER BEARINGS

200-260 mm

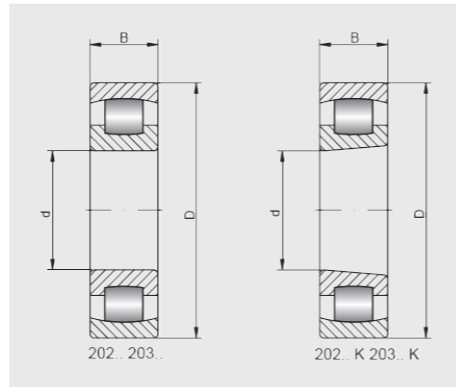

Shaft (mm)	Bearing No.	Series		Sleeve no. H.	Dimensions [mm]			
		SD	SB		d	D	B	
200 cont.	22240 CW33	2	2	-	200	360	98	
	22240 KCW33	2	2	H3140	200	360	98	
	23240 CW33	2	3	-	200	360	128	
	23240 KCW33	2	3	H2340	200	360	128	
220	22340 CW33	3	2	-	200	420	138	
	22340 KCW33	3	2	H2340	200	420	138	
	23340 CW33	3	3	-	200	420	165	
	23944 CW33	9	3	-	220	300	60	
	23944 KCW33	9	3	H3944	220	300	60	
	23044 CW33	0	3	-	220	340	90	
	23044 KCW33	0	3	H3044	220	340	90	
	24044 CW33	0	4	-	220	340	118	
	24044 K30CW33	0	4	-	220	340	118	
	23144 CW33	1	3	-	220	370	120	
23144 KCW33	1	3	H3144	220	370	120		
24144 CW33	1	4	-	220	370	150		
24144 K30CW33	1	4	-	220	370	150		
20244 C	2	0	-	220	400	65		
22244 CW33	2	2	-	220	400	108		
22244 KCW33	2	2	H3144	220	400	108		
23244 CW33	2	3	-	220	400	144		
23244 KCW33	2	3	H2344	220	400	144		
22344 CW33	3	2	-	220	460	145		
22344 KCW33	3	2	H2344	220	460	145		
240	23948 CW33	9	3	-	240	320	60	
	23948 KCW33	9	3	H3948	240	320	60	
	23048 CW33	0	3	-	240	360	92	
	23048 KCW33	0	3	H3048	240	360	92	
	24048 CW33	0	4	-	240	360	118	
	24048 K30CW33	0	4	-	240	360	118	
	23148 CW33	1	3	-	240	400	128	
	23148 KCW33	1	3	H3148	240	400	128	
	24148 CW33	1	4	-	240	400	160	
	24148 K30CW33	1	4	-	240	400	160	
	20248 C	2	0	-	240	440	72	
	22248 CW33	2	2	-	240	440	120	
	22248 KCW33	2	2	H3148	240	440	120	
	240 cont.	23248 CW33	2	3	-	240	440	160
		23248 KCW33	2	3	H2348	240	440	160
		22348 CW33	3	2	-	240	500	155
22348 KCW33		3	2	H2348	240	500	155	
260	23952 CW33	9	3	-	260	360	75	
	23952 KCW33	9	3	H3952	260	360	75	
	23052 CW33	0	3	-	260	400	104	
	23052 KCW33	0	3	H3052	260	400	104	
	24052 CW33	0	4	-	260	400	140	

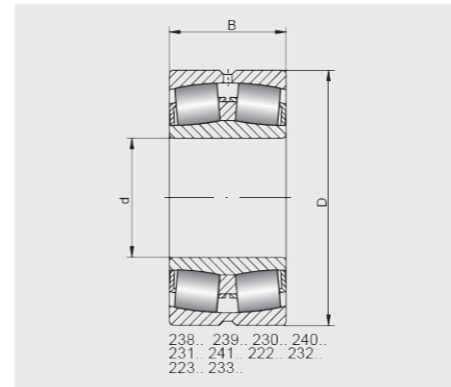

Basic makes	
-	M
✓	✓
TV	C3
✓	✓
C4	
✓	

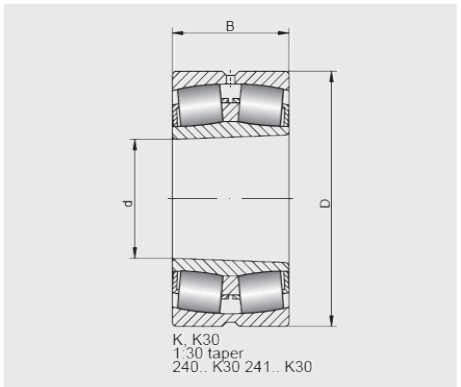

Weight (kg)	Basic load ratings (kN)		Limiting speed (rpm)		Bearing No.
	dyn. C	stat. C0	grease	oil	
43,5	1270	1930	1100	1500	22240 CW33
43,2	1270	1930	1100	1500	22240 KCW33
57	1610	2700	850	1100	23240 CW33
57,6	1610	2700	850	1100	23240 KCW33
92,5	2020	2900	850	1100	22340 CW33
90,4	2020	2900	850	1100	22340 KCW33
108	2450	3600	800	1050	23340 CW33
13	546	1080	1500	1900	23944 CW33
12,2	546	1080	1500	1900	23944 KCW33
30,5	1050	1860	1100	1500	23044 CW33
30,2	1050	1860	1100	1500	23044 KCW33
39,5	1360	2600	850	1100	24044 CW33
39,5	1360	2600	850	1100	24044 K30CW33
53	1580	2750	900	1200	23144 CW33
52,5	1580	2750	900	1200	23144 KCW33
65	1840	3350	500	630	24144 CW33
65	1840	3350	500	630	24144 K30CW33
37,4	880	1320	750	1000	20244 C
60,5	1520	2360	950	1300	22244 CW33
59,6	1520	2360	950	1300	22244 KCW33
79,5	2070	3450	750	950	23244 CW33
81,4	2070	3450	750	950	23244 KCW33
120	2350	3450	750	950	22344 CW33
117	2350	3450	750	950	22344 KCW33
14	564	1160	1300	1700	23948 CW33
13,5	564	1160	1300	1700	23948 KCW33
33,5	1130	2080	1000	1400	23048 CW33
33	1130	2080	1000	1400	23048 KCW33
42,5	1380	2700	800	1000	24048 CW33
43,5	1380	2700	800	1000	24048 K30CW33
65,5	1790	3200	850	1100	23148 CW33
65	1790	3200	850	1100	23148 KCW33
80,5	2100	3900	480	600	24148 CW33
80,5	2100	3900	480	600	24148 K30CW33
50,5	1060	1600	750	750	20248 C
83	1910	3000	900	1200	22248 CW33
81,2	1910	3000	900	1200	22248 KCW33
110	2530	4300	670	850	23248 CW33
108	2530	4300	670	850	23248 KCW33
155	2670	4000	670	850	22348 CW33
149	2670	4000	670	850	22348 KCW33
24	880	1800	1100	1500	23952 CW33
22,4	880	1800	1100	1500	23952 KCW33
48,5	1400	2550	900	1200	23052 CW33
47,9	1400	2550	900	1200	23052 KCW33
64,5	1760	3450	700	900	24052 CW33

1.1 SINGLE-ROW AND DOUBLE-ROW SPHERICAL ROLLER BEARINGS

260-300 mm

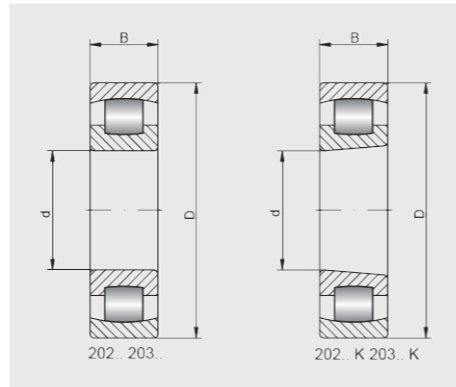

Shaft (mm)	Bearing No.	Series		Sleeve no.		Dimensions [mm]			
		SD	SB	H.	AH.	d	D	B	
260 cont.	24052 K30CW33	0	4	-	AH24052	260	400	140	
	23152 CW33	1	3	-	-	260	440	144	
	23152 KCW33	1	3	H3152	AH3152	260	440	144	
	24152 CW33	1	4	-	-	260	440	180	
	24152 K30CW33	1	4	-	AH24152	260	440	180	
	20252 C	2	0	-	-	260	480	80	
	22252 CW33	2	2	-	-	260	480	130	
	22252 KCW33	2	2	H3152	AH2252	260	480	130	
	23252 CW33	2	3	-	-	260	480	174	
	23252 KCW33	2	3	H2352	AH2352	260	480	174	
	22352 CW33	3	2	-	-	260	540	165	
	22352 KCW33	3	2	H2352	AH2352	260	540	165	
	280	23956 CW33	9	3	-	-	280	380	75
		23956 KCW33	9	3	H3956	AH3956	280	380	75
		23056 CW33	0	3	-	-	280	420	106
23056 KCW33		0	3	H3056	AH3056	280	420	106	
24056 CW33		0	4	-	-	280	420	140	
23156 CW33		1	3	-	-	280	460	146	
23156 KCW33		1	3	H3156	AH3156	280	460	146	
24156 CW33		1	4	-	-	280	460	180	
24156 K30CW33		1	4	-	AH24156	280	460	180	
22256 CW33		2	2	-	-	280	500	130	
22256 KCW33		2	2	H3156	AH2256	280	500	130	
23256 CW33		2	3	-	-	280	500	176	
23256 KCW33		2	3	H2356	AH2356	280	500	176	
22356 CW33		3	2	-	-	280	580	175	
22356 KCW33		3	2	H2356	AH2356	280	580	175	
300	23960 CW33	9	3	-	-	300	420	90	
	23960 KCW33	9	3	H3960	AH3960	300	420	90	
	23060 CW33	0	3	-	-	300	460	118	
	23060 KCW33	0	3	H3060	AH3060	300	460	118	
	24060 CW33	0	4	-	-	300	460	160	
	24060 K30CW33	0	4	-	AH24056	300	460	160	
	23160 CW33	1	3	-	-	300	500	160	
	23160 KCW33	1	3	H3160	AH3160	300	500	160	
	24160 CW33	1	4	-	-	300	500	200	
	24160 K30CW33	1	4	-	AH24160	300	500	200	
	22260 CW33	2	2	-	-	300	540	140	
	22260 KCW33	2	2	H3160	AH2260	300	540	140	
	23260 CW33	2	3	-	-	300	540	192	
	23260 KCW33	2	3	H3260	AH3260	300	540	192	
	22360 CW33	3	2	-	-	300	620	185	
22360 KCW33	3	2	-	-	300	620	185		

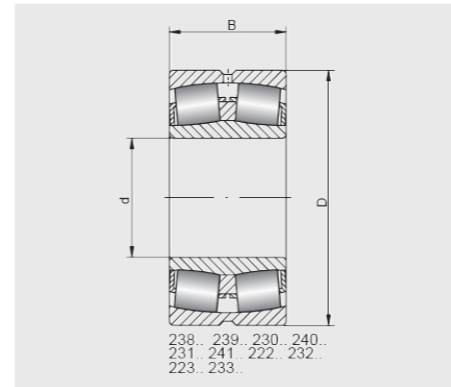

Basic makes	
-	M
✓	✓
TV	C3
✓	✓
C4	
✓	

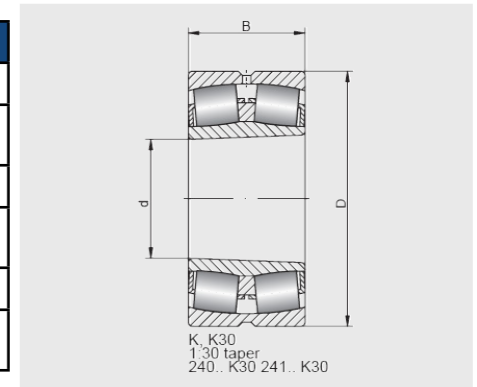

Weight (kg)	Basic load ratings (kN)		Limiting speed (rpm)		Bearing No.
	dyn. C	stat. C0	grease	oil	
65	1760	3450	700	900	24052 K30CW33
90,5	2220	3900	800	1000	23152 CW33
93	2220	3900	800	1000	23152 KCW33
110	2620	4800	430	530	24152 CW33
110	2620	4800	430	530	24152 K30CW33
68,2	1270	1930	500	750	20252 C
110	2300	3550	850	1100	22252 CW33
108	2300	3550	850	1100	22252 KCW33
140	2820	4750	630	800	23252 CW33
140	2820	4750	630	800	23252 KCW33
190	3050	4550	630	800	22352 CW33
181	3050	4550	630	800	22352 KCW33
26	965	2040	1000	1400	23956 CW33
25,1	965	2040	1000	1400	23956 KCW33
52,5	1520	2850	850	1100	23056 CW33
52,2	1520	2850	850	1100	23056 KCW33
68,5	1870	3800	670	850	24056 CW33
97	2300	4250	750	950	23156 CW33
96,4	2300	4250	750	950	23156 KCW33
120	2670	5100	400	500	24156 CW33
120	2670	5100	400	500	24156 K30CW33
115	2350	3750	800	1000	22256 CW33
112	2350	3750	800	1000	22256 KCW33
150	2820	4900	600	750	23256 CW33
152	2820	4900	600	750	23256 KCW33
235	3450	5200	600	750	22356 CW33
230	3450	5200	600	750	22356 KCW33
40,5	1200	2500	950	1300	23960 CW33
40,4	1200	2500	950	1300	23960 KCW33
71,5	1840	3450	800	1000	23060 CW33
72,3	1840	3450	800	1000	23060 KCW33
97	2350	4750	600	750	24060 CW33
98,7	2350	4750	600	750	24060 K30CW33
125	2820	5100	670	850	23160 CW33
127	2820	5100	670	850	23160 KCW33
155	3280	6300	360	450	24160 CW33
155	3280	6300	360	450	24160 K30CW33
145	2760	4250	750	950	22260 CW33
140	2760	4250	750	950	22260 KCW33
190	3340	5850	530	670	23260 CW33
192	3340	5850	530	670	23260 KCW33
289	3910	5430	470	630	22360 CW33
284	3910	5430	470	630	22360 KCW33

1.2 SPHERICAL ROLLER BEARINGS WITH ADAPTER SLEEVE

20-70 mm

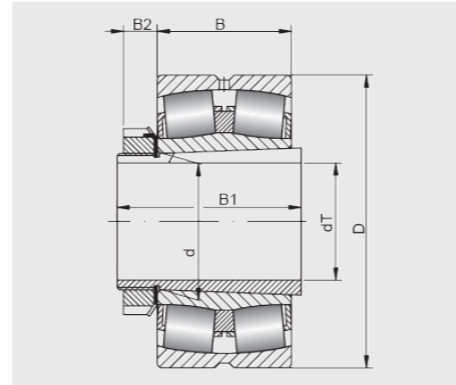

Shaft (mm)	Bearing No.	Series		Sleeve no.	Dimensions [mm]					
		SD	SB		H.	d	dT	D	B	B1
20	20205 KC	2	0	H205	25	20	52	15	26	9
	22205 KCW33	2	2	H305	25	20	52	18	29	8
25	20206 KC	2	0	H206	30	25	62	16	27	9
	22206 KCW33	2	2	H306	30	25	62	20	31	8
30	20207 KC	2	0	H207	35	30	72	17	29	10
	22207 KCW33	2	2	H307	35	30	72	23	35	9
35	20208 KC	2	0	H208	40	35	80	18	31	11
	22208 KCW33	2	2	H308	40	35	80	23	36	10
40	20209 KC	2	0	H209	45	40	85	19	33	12
	22209 KCW33	2	2	H309	45	40	85	23	39	11
45	20210 KC	2	0	H210	50	45	90	20	35	13
	22210 KCW33	2	2	H310	50	45	90	23	42	12
50	20211 KC	2	0	H211	55	50	100	21	37	14
	22211 KCW33	2	2	H311	55	50	100	25	45	12
55	20212 KC	2	0	H212	60	55	110	22	38	14
	22212 KCW33	2	2	H312	60	55	110	31	47	13
60	20213 KC	2	0	H213	65	60	120	23	40	15
	22213 KCW33	2	2	H313	65	60	120	31	50	14
65	20215 KC	2	0	H215	75	65	130	25	43	16
	22215 KCW33	2	2	H315	75	65	130	31	55	15
70	20216 KC	2	0	H216	80	70	140	26	46	18
	22216 KCW33	2	2	H316	80	70	140	33	59	17

Basic makes				
-	M	TV	C3	C4
✓	✓	✓	✓	✓

Weight (kg)	Basic load ratings (kN)		Limiting speed (rpm)		Bearing No.
	dyn. C	stat. C0	grease	oil	
0,145	24	25	5000	6500	20205 KC
0,163	43.1	44	8500	11000	22205 KCW33
0,228	27.5	28.5	4000	5500	20206 KC
0,26	48.9	52	7500	9500	22206 KCW33
0,38	55.2	61	6000	7500	21306 KCW33
0,301	40.5	43	3500	4750	20207 KC
0,405	67.3	73.5	6300	8000	22207 KCW33
0,502	65.6	72	5300	6700	21307 KCW33
0,389	49	53	3250	4250	20208 KC
0,487	73.6	81.5	6000	7500	22208 KCW33
0,706	82.8	98	4500	5600	21308 KCW33
0,984	115	122	4500	5600	22308 KCW33
0,483	52	57	3000	4000	20209 KC
0,57	77.1	88	5300	6700	22209 KCW33
0,947	101	114	4300	5300	21309 KCW33
1,36	138	160	3800	4800	22309 KCW33
0,49	58.5	68	2750	3500	20210 KC
0,582	84.5	100	5000	6300	22210 KCW33
1,21	120	140	3600	4800	21310 KCW33
1,7	176	200	3400	4300	22310 KCW33
0,78	73.5	85	2500	3250	20211 KC
0,8	99.5	118	4500	5600	22211 KCW33
1,64	120	137	2250	3000	20311 KC
1,55	138	163	3400	4300	21311 KCW33
2,02	199	232	3200	4000	22311 KCW33
0,93	85	100	2500	3250	20212 KC
1	122	146	4000	5000	22212 KCW33
2	146	170	2000	2750	20312 KC
1,93	161	200	3000	3800	21312 KCW33
2,8	235	280	3000	3800	22312 KCW33
1,19	95	116	2250	3000	20213 KC
1,27	176	216	3800	4800	22213 KCW33
1,46	148	186	3600	4500	22214 KCW33
2,53	170	196	2000	2750	20313 KC
2,42	184	240	2800	3600	21313 KCW33
3,57	253	300	2600	3400	22313 KCW33
3,5	253	300	2600	3400	22313 KCW33
2,95	207	260	2600	3400	21314 KCW33
4,25	311	380	2400	3200	22314 KCW33
1,4	112	143	2000	2750	20215 KC
1,65	158	208	3400	4300	22215 KCW33
3,55	235	300	2400	3200	21315 KCW33
5,01	345	430	2200	3000	22315 KCW33
1,72	125	163	2000	2500	20216 KC
1,97	176	228	3200	4000	22216 KCW33
4,23	258	335	2200	3000	21316 KCW33
5,95	374	455	2000	2800	22316 KCW33

1.2 SPHERICAL ROLLER BEARINGS WITH ADAPTER SLEEVE

75-135 mm
Z&S BEARINGS PRODUCTION

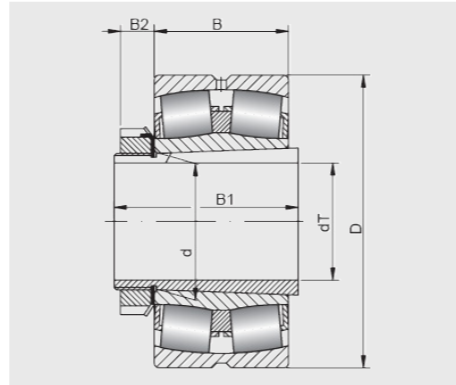

Shaft (mm)	Bearing No.	Series		Sleeve no. H.	Dimensions [mm]						
		SD	SB		d	dT	D	B	B1	B2	
75	20217 KC	2	0	H217	85	75	150	28	50	19	
	22217 KCW33	2	2	H317	85	75	150	36	63	18	
	21317 KCW33	3	0	H317	85	75	180	41	63	18	
80	22317 KCW33	3	2	H2317	85	75	180	60	82	18	
	20218 KC	2	0	H218	90	80	160	30	52	19	
	22218 KCW33	2	2	H318	90	80	160	40	65	18	
80	23218 KCW33	2	3	H2318	90	80	160	52.4	86	18	
	20318 KC	3	0	H318	90	80	190	43	65	19	
	21318 KCW33	3	0	H318	90	80	190	43	65	18	
	22318 KCW33	3	2	H2318	90	80	190	64	86	18	
	22219 KCW33	2	2	H319	95	85	170	43	68	19	
	21319 KCW33	3	0	H319	95	85	200	45	68	19	
85	22319 KCW33	3	2	H2319	95	85	200	67	90	19	
	23120 KCW33	1	3	H3120	100	90	165	52	76	20	
	20220 KC	2	0	H220	100	90	180	34	58	21	
90	22220 KCW33	2	2	H320	100	90	180	46	71	20	
	22220 KCW33	2	2	H220	100	90	180	46	58	20	
	23220 KCW33	2	3	H2320	100	90	180	60.3	97	20	
	20320 KC	3	0	H320	100	90	215	47	71	21	
	21320 KCW33	3	0	H320	100	90	215	47	71	20	
	22320 KCW33	3	2	H2320	100	90	215	73	97	20	
	100	23122 KCW33	1	3	H3122	110	100	180	56	81	21
		20222 KC	2	0	H222	110	100	200	38	63	21
		22222 KCW33	2	2	H322	110	100	200	53	77	21
		23222 KCW33	2	3	H2322	110	100	200	70	105	21
21322 KCW33		3	0	H322	110	100	240	50	77	21	
110	22322 KCW33	3	2	H2322	110	100	240	80	105	21	
	23024 KCW33	0	3	H3024	120	110	180	46	72	22	
	23124 KCW33	1	3	H3124	120	110	200	62	88	22	
	20224 KC	2	0	H3024	120	110	215	40	72	22	
	22224 KCW33	2	2	H3124	120	110	215	58	88	22	
115	23224 KCW33	2	3	H2324	120	110	215	76	112	22	
	22324 KCW33	3	2	H2324	120	110	260	86	112	22	
	23026 KCW33	0	3	H3026	130	115	200	52	80	23	
	23126 KCW33	1	3	H3126	130	115	210	64	92	23	
	20226 KC	2	0	H3026	130	115	230	40	80	23	
	22226 KCW33	2	2	H3126	130	115	230	64	92	23	
125	23226 KCW33	2	3	H2326	130	115	230	80	121	23	
	22326 KCW33	3	2	H2326	130	115	280	93	121	23	
	23028 KCW33	0	3	H3028	140	125	210	53	82	24	
	23128 KCW33	1	3	H3128	140	125	225	68	97	24	
	20228 KC	2	0	H3028	140	125	250	42	82	24	
	22228 KCW33	2	2	H3128	140	125	250	68	97	24	
135	23228 KCW33	2	3	H2328	140	125	250	88	131	24	
	22328 KCW33	3	2	H2328	140	125	300	102	131	24	
	23030 KCW33	0	3	H3030	150	135	225	56	87	26	
	23130 KCW33	1	3	H3130	150	135	250	80	111	26	
	20230 KC	2	0	H3030	150	135	270	45	87	26	
22230 KCW33	2	2	H3130	150	135	270	73	111	26		

Basic makes				
-	M	TV	C3	C4
✓	✓	✓	✓	✓

Weight (kg)	Basic load ratings (kN)		Limiting speed (rpm)		Bearing No.
	dyn. C	stat. C0	grease	oil	
2.14	156	200	1750	2500	20217 KC
2.49	210	270	3000	3800	22217 KCW33
4.93	293	375	2000	2800	21317 KCW33
6.84	420	520	1900	2600	22317 KCW33
2.63	173	220	1500	2000	20218 KC
3.2	253	340	2600	3400	22218 KCW33
4.2	311	440	1900	2600	23218 KCW33
6.03	300	360	1500	2000	20318 KC
5.74	322	425	1900	2600	21318 KCW33
8.08	477	610	1800	2400	22318 KCW33
3.89	282	375	2400	3200	22219 KCW33
6.63	351	480	1800	2400	21319 KCW33
9.21	518	670	1800	2400	22319 KCW33
4.2	322	490	2000	2800	23120 KCW33
3.81	224	290	1500	2000	20220 KC
4.72	311	415	2200	3000	22220 KCW33
4.72	311	415	2200	3000	22220 KCW33
6.2	414	600	1700	2200	23220 KCW33
8.46	365	440	1250	1750	20320 KC
8.19	385	530	1700	2200	21320 KCW33
11.7	610	800	1700	2200	22320 KCW33
5.13	374	585	1900	2600	23122 KCW33
5.34	285	375	1250	1750	20222 KC
7.1	408	560	2000	2800	22222 KCW33
9.1	518	765	1600	2000	23222 KCW33
11.1	460	630	1600	2000	21322 KCW33
17.4	725	965	1600	2000	22322 KCW33
4.22	305	510	2000	2800	23024 KCW33
7.3	449	695	1800	2400	23124 KCW33
6.41	305	415	1250	1750	20224 KC
8.72	466	670	1900	2600	22224 KCW33
11	610	930	1500	1900	23224 KCW33
21	845	1120	1400	1800	22324 KCW33
5.6	374	610	1900	2600	23026 KCW33
8.1	489	780	1700	2200	23126 KCW33
7.19	335	450	1250	1500	20226 KC
10.4	546	800	1800	2400	22226 KCW33
13	690	1060	1300	1700	23226 KCW33
26.7	978	1320	1300	1700	22326 KCW33
6	397	680	1800	2400	23028 KCW33
9.8	546	900	1600	2000	23128 KCW33
9	390	530	1000	1500	20228 KC
13.5	610	900	1700	2200	22228 KCW33
17.7	799	1250	1200	1600	23228 KCW33
34	1130	1560	1100	1500	22328 KCW33
7	437	750	1700	2200	23030 KCW33
15	725	1200	1400	1800	23130 KCW33
11.5	430	610	1000	1250	20230 KC
17	736	1080	1600	2000	22230 KCW33

1.2 SPHERICAL ROLLER BEARINGS WITH ADAPTER SLEEVE

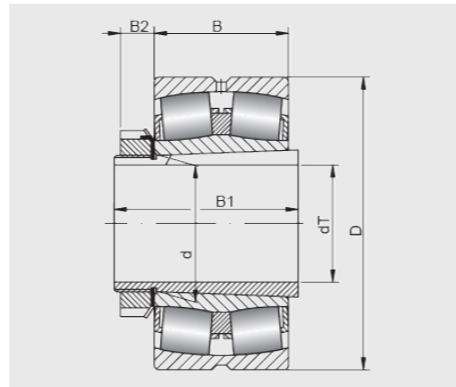

Shaft (mm)	Bearing No.	Series		Sleeve no. H.	Dimensions [mm]					
		SD	SB		d	dT	D	B	B1	B2
135 cont.	23230 KCW33	2	3	H2330	150	135	270	96	139	26
	22330 KCW33	3	2	H2330	150	135	320	108	139	26
140	23032 KCW33	0	3	H3032	160	140	240	60	93	28
	23132 KCW33	1	3	H3132	160	140	270	86	119	28
	20232 KC	2	0	H3032	160	140	290	48	93	28
	22232 KCW33	2	2	H3132	160	140	290	80	119	28
	23232 KCW33	2	3	H2332	160	140	290	104	147	28
150	22332 KCW33	3	2	H2332	160	140	340	114	147	28
	23034 KCW33	0	3	H3034	170	150	260	67	101	29
	23134 KCW33	1	3	H3134	170	150	280	88	122	29
	22234 KCW33	2	2	H3134	170	150	310	86	122	29
	23234 KCW33	2	3	H2334	170	150	310	110	154	29
160	22334 KCW33	3	2	H2334	170	150	360	120	154	29
	23936 KCW33	9	3	H3936	180	160	250	52	87	30
	23036 KCW33	0	3	H3036	180	160	280	74	109	30
	23136 KCW33	1	3	H3136	180	160	300	96	131	30
	22236 KCW33	2	2	H3136	180	160	320	86	131	30
170	23236 KCW33	2	3	H2336	180	160	320	112	161	30
	22336 KCW33	3	2	H2336	180	160	380	126	161	30
	23938 KCW33	9	3	H3938	190	170	260	52	89	31
	23038 KCW33	0	3	H3038	190	170	290	75	112	31
	23138 KCW33	1	3	H3138	190	170	320	104	141	31
180	22238 KCW33	2	2	H3138	190	170	340	92	141	31
	23238 KCW33	2	3	H2338	190	170	340	120	169	31
	22338 KCW33	3	2	H2338	190	170	400	132	169	31
	23940 KCW33	9	3	H3940	200	180	280	60	98	32
	23040 KCW33	0	3	H3040	200	180	310	82	120	32
200	23140 KCW33	1	3	H3140	200	180	340	112	150	32
	22240 KCW33	2	2	H3140	200	180	360	98	150	32
	23240 KCW33	2	3	H2340	200	180	360	128	176	32
	22340 KCW33	3	2	H2340	200	180	420	138	176	32
	23944 KCW33	9	3	H3944	220	200	300	60	96	30
220	23044 KCW33	0	3	H3044	220	200	340	90	126	30
	23144 KCW33	1	3	H3144	220	200	370	120	161	35
	22244 KCW33	2	2	H3144	220	200	400	108	161	35
	23244 KCW33	2	3	H2344	220	200	400	144	186	35
	22344 KCW33	3	2	H2344	220	200	460	145	186	35
240	23948 KCW33	9	3	H3948	240	220	320	60	101	34
	23048 KCW33	0	3	H3048	240	220	360	92	133	34
	23148 KCW33	1	3	H3148	240	220	400	128	172	37
	22248 KCW33	2	2	H3148	240	220	440	120	172	37
	23248 KCW33	2	3	H2348	240	220	440	160	199	37
240	22348 KCW33	3	2	H2348	240	220	500	155	199	37
	23952 KCW33	9	3	H3952	260	240	360	75	116	34
	23052 KCW33	0	3	H3052	260	240	400	104	145	34
	23152 KCW33	1	3	H3152	260	240	440	144	190	39
	22252 KCW33	2	2	H3152	260	240	480	130	190	39
23252 KCW33	2	3	H2352	260	240	480	174	211	39	

Basic makes				
-	M	TV	C3	C4
✓	✓	✓	✓	✓

Weight (kg)	Basic load ratings (kN)		Limiting speed (rpm)		Bearing No.
	dyn. C	stat. C0	grease	oil	
22	937	1460	1100	1500	23230 KCW33
40.6	1270	1760	1000	1400	22330 KCW33
8	506	880	1700	2200	23032 KCW33
19	845	1370	1300	1700	23132 KCW33
14.3	500	720	1000	1250	20232 KC
22.5	863	1290	1500	1900	22232 KCW33
28.9	1070	1660	1000	1400	23232 KCW33
50.5	1380	1960	950	1300	22332 KCW33
12.1	621	1060	1600	2000	23034 KCW33
20.6	897	1500	1200	1600	23134 KCW33
26.3	978	1460	1300	1700	22234 KCW33
34.2	1220	1930	950	1300	23234 KCW33
58.2	1540	2160	950	1300	22334 KCW33
7.7	431	830	1700	2200	23936 KCW33
16.6	725	1250	1400	1800	23036 KCW33
26.8	1050	1760	1100	1500	23136 KCW33
28.5	1010	1560	1300	1700	22236 KCW33
38.6	1290	2120	900	1200	23236 KCW33
68.5	1730	2450	900	1200	22336 KCW33
8.3	414	800	1700	2200	23938 KCW33
16.9	753	1340	1300	1700	23038 KCW33
31.4	1200	2080	1000	1400	23138 KCW33
37	1110	1700	1200	1600	22238 KCW33
47.5	1460	2400	850	1100	23238 KCW33
79.4	1870	2650	850	1100	22338 KCW33
12.3	546	1040	1600	2000	23940 KCW33
22.3	880	1530	1200	1600	23040 KCW33
41.6	1380	2360	950	1300	23140 KCW33
43.2	1270	1930	1100	1500	22240 KCW33
57.6	1610	2700	850	1100	23240 KCW33
90.4	2020	2900	850	1100	22340 KCW33
12.2	546	1080	1500	1900	23944 KCW33
30.2	1050	1860	1100	1500	23044 KCW33
52.5	1580	2750	900	1200	23144 KCW33
59.6	1520	2360	950	1300	22244 KCW33
81.4	2070	3450	750	950	23244 KCW33
117	2350	3450	750	950	22344 KCW33
13.5	564	1160	1300	1700	23948 KCW33
33	1130	2080	1000	1400	23048 KCW33
65	1790	3200	850	1100	23148 KCW33
81.2	1910	3000	900	1200	22248 KCW33
108	2530	4300	670	850	23248 KCW33
149	2670	4000	670	850	22348 KCW33
22.4	880	1800	1100	1500	23952 KCW33
47.9	1400	2550	900	1200	23052 KCW33
93	2220	3900	800	1000	23152 KCW33
108	2300	3550	850	1100	22252 KCW33
140	2820	4750	630	800	23252 KCW33

1.2 SPHERICAL ROLLER BEARINGS WITH ADAPTER SLEEVE

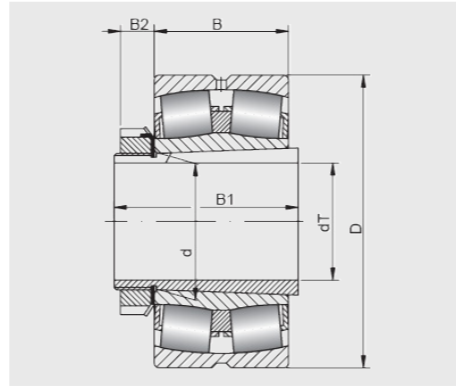

Shaft (mm)	Bearing No.	Series		Sleeve no. H.	Dimensions [mm]					
		SD	SB		d	dT	D	B	B1	B2
240 cont.	22352 KCW33	3	2	H2352	260	240	540	165	211	39
	23956 KCW33	9	3	H3956	280	260	380	75	121	38
260	23056 KCW33	0	3	H3056	280	260	420	106	152	38
	23156 KCW33	1	3	H3156	280	260	460	146	195	41
	22256 KCW33	2	2	H3156	280	260	500	130	195	41
	23256 KCW33	2	3	H2356	280	260	500	176	224	41
	22356 KCW33	3	2	H2356	280	260	580	175	224	41
	23960 KCW33	9	3	H3960	300	280	420	90	140	42
280	23060 KCW33	0	3	H3060	300	280	460	118	168	42
	23160 KCW33	1	3	H3160	300	280	500	160	208	40
	22260 KCW33	2	2	H3160	300	280	540	140	208	40
	23260 KCW33	2	3	H3260	300	280	540	192	240	40
	23964 KCW33	9	3	H3964	320	300	440	90	140	42
300	23064 KCW33	0	3	H3064	320	300	480	121	171	42
	23164 KCW33	1	3	H3164	320	300	540	176	226	42
	22264 KCW33	2	2	H3164	320	300	580	150	226	42
	23264 KCW33	2	3	H3264	320	300	580	208	258	42

Basic makes				
-	M	TV	C3	C4
✓	✓	✓	✓	✓

Weight (kg)	Basic load ratings (kN)		Limiting speed (rpm)		Bearing No.
	dyn. C	stat. C0	grease	oil	
181	3050	4550	630	800	22352 KCW33
25.1	965	2040	1000	1400	23956 KCW33
52.2	1520	2850	850	1100	23056 KCW33
96.4	2300	4250	750	950	23156 KCW33
112	2350	3750	800	1000	22256 KCW33
152	2820	4900	600	750	23256 KCW33
230	3450	5200	600	750	22356 KCW33
40.4	1200	2500	950	1300	23960 KCW33
72.3	1840	3450	800	1000	23060 KCW33
127	2820	5100	670	850	23160 KCW33
140	2760	4250	750	950	22260 KCW33
192	3340	5850	530	670	23260 KCW33
40.7	1240	2700	900	1200	23964 KCW33
77.8	1960	3800	800	1000	23064 KCW33
164	3280	6000	630	800	23164 KCW33
171	3050	4900	490	660	22264 KCW33
237	3850	6700	500	630	23264 KCW33

2. SPHERICAL ROLLER THRUST BEARINGS

A. Dimension series

- 292.. 293.. 294..

B. Structure

- Spherical roller thrust bearings are single-row, detachable bearings consisting of an inner ring with an integrated cage retaining asymmetrically arranged spherical rollers, and a separate outer ring. This design allows the inner ring with the roller assembly and the outer ring to be mounted independently, simplifying installation and handling

C. Cages

- Cages of spherical roller thrust bearings are predominantly manufactured from brass, with steel cages used in certain designs and applications.

D. Features

- Spherical roller thrust bearings transmit loads obliquely from one raceway to the other and, unlike conventional thrust bearings, are capable of accommodating radial loads in combination with axial loads.
- A key feature of these bearings is their self-aligning capability, which provides resistance to shaft deflection and alignment inaccuracies.
- Depending on the bearing series, applied load, rotational speed, and which ring rotates, the permissible angular misalignment typically ranges from 1° to 3°. For reliable and efficient operation, a sufficient axial load is essential: the axial load must exceed 55 % of the radial load. If the external load or the weight of machine components acting on the bearing is insufficient, an additional axial load—such as that generated by springs—must be applied.

E. Features

- Spherical roller thrust bearings transmit loads obliquely from one raceway to the other and, unlike conventional thrust bearings, are capable of accommodating radial loads in combination with axial loads.
- A key feature of these bearings is their self-aligning capability, which provides resistance to shaft deflection and alignment inaccuracies.
- Depending on the bearing series, applied load, rotational speed, and which ring rotates, the permissible angular misalignment typically ranges from 1° to 3°. For reliable and efficient operation, a sufficient axial load is essential: the axial load must exceed 55 % of the radial load. If the external load or the weight of machine components acting on the bearing is insufficient, an additional axial load—such as that generated by springs—must be applied.

F. Comparison between thrust ball bearings and spherical roller thrust bearings

- The table below provides a comparison of the performance capabilities of thrust ball bearings and spherical roller thrust bearings.
- In this comparison, spherical roller thrust bearings exhibit superior load capacity as well as higher permissible rotational speed. In addition, due to the oblique arrangement of spherical rollers relative to the bearing axis, spherical roller thrust bearings are capable of accommodating both axial and radial loads.

Bearing type	53320	29320
Dynamic load rating [kN]	236	408
Rotational speed (grease) [rpm]	940	1500

2.1 SPHERICAL ROLLER THRUST BEARINGS



60-240
mm
Z&S BEARINGS PRODUCTION

Shaft (mm)	Bearing No.	Series		Dimensions [mm]					
		SD	SB	d	d1	D	D1	C	T
60	29412 M	4	9	60	89	130	123	20	42
65	29413 M	4	9	65	96	140	133	21	45
70	29414 M	4	9	70	103	150	142	23	48
75	29415 M	4	9	75	109	160	152	24	51
80	29416 M	4	9	80	117	170	162	26	54
85	29317 M	3	9	85	114	150	143,5	19	39
	29417 M	4	9	85	125	180	170	28	58
90	29318 M	3	9	90	117	155	148,5	19	39
	29418 M	4	9	90	132	190	180	29	60
100	29320 M	3	9	100	129	170	163	20,8	42
	29420 M	4	9	100	146	210	200	32	67
110	29322 M	3	9	110	143	190	182	23	48
	29422 M	4	9	110	162	230	220	35	73
120	29324 M	3	9	120	159	210	200	26	54
	29424 M	4	9	120	174	250	236	37	78
130	29326 M	3	9	130	171	225	215	28	58
	29426 M	4	9	130	189	270	255	41	85
140	29328 M	3	9	140	183	240	230	29	60
	29428 M	4	9	140	199	280	268	41	85
150	29330 M	3	9	150	194	250	240	29	60
	29430 M	4	9	150	214	300	285	44	90
160	29332 M	3	9	160	208	270	260	32	67
	29432 M	4	9	160	229	320	306	45	95
170	29334 M	3	9	170	216	280	270	32	67
	29434 M	4	9	170	243	340	324	50	103
180	29336 M	3	9	180	232	300	290	35	73
	29436 M	4	9	180	255	360	342	52	109
190	29338 M	3	9	190	246	320	308	38	78
	29438 M	4	9	190	271	380	360	55	115
200	29240 M	2	9	200	236	280	271	24	48
	29340 M	3	9	200	261	340	325	41	85
	29440 M	4	9	200	286	400	380	59	122
220	29244 M	2	9	220	254	300	292	24	48
	29344 M	3	9	220	280	360	345	41	85
	29444 M	4	9	220	308	420	400	58	122
240	29248 M	2	9	240	283	340	330	30	60
	29348 M	3	9	240	300	380	365	41	85

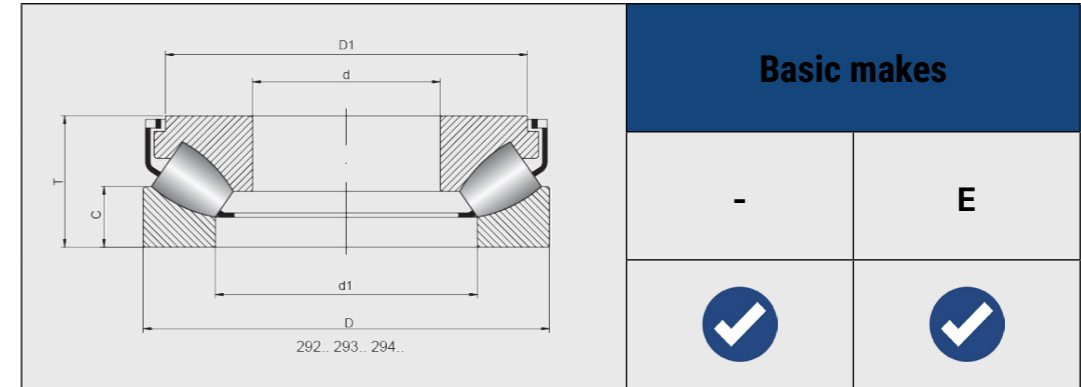

Weight (kg)	Basic load ratings (kN)		Limiting speed (rpm)		Bearing No.
	dyn. C	stat. C0	grease	oil	
2,6	345	915	1800	2600	29412 M
3,2	397	1080	1700	2400	29413 M
3,9	449	1250	1600	2200	29414 M
4,7	518	1430	1600	2200	29415 M
5,6	575	1630	1500	2000	29416 M
2,82	287	927	1700	2300	29317 M
6,75	633	1800	1300	1800	29417 M
2,85	345	1080	1600	2200	29318 M
7,75	702	2000	1300	1800	29418 M
3,65	408	1290	1500	2000	29320 M
10,5	863	2500	1100	1600	29420 M
5,3	535	1730	1300	1800	29322 M
13,5	1010	3000	950	1400	29422 M
7,35	656	2120	1100	1600	29324 M
17,5	1170	3450	900	1300	29424 M
9	753	2500	1000	1500	29326 M
22	1380	4050	850	1200	29426 M
10,5	845	2850	950	1400	29328 M
23	1400	4300	850	1200	29428 M
11	863	2850	950	1400	29330 M
28	1610	5100	800	1100	29430 M
14,5	1010	3450	850	1200	29332 M
33,5	1790	5600	750	1000	29432 M
15	1050	3550	850	1200	29334 M
44,5	2020	6550	700	950	29434 M
19,5	1240	4300	800	1100	29336 M
52,5	2250	7350	670	900	29436 M
23,5	1400	4750	750	1000	29338 M
60,5	2480	8000	630	850	29438 M
8,9	536	2270	-	1400	29240 M
29,5	1610	5500	700	950	29340 M
72	2760	9000	600	800	29440 M
10	542	2490	-	1300	29244 M
34,5	1730	6300	700	950	29344 M
75	2880	9650	560	750	29444 M
16,7	822	3680	-	1100	29248 M
36,3	1790	6550	670	900	29348 M

2.1 SPHERICAL ROLLER THRUST BEARINGS



Shaft (mm)	Bearing No.	Series		Dimensions [mm]					
		SD	SB	d	d1	D	D1	C	T
240 cont.	29448 M	4	9	240	326	440	420	59	122
	29252 M	2	9	260	302	360	350	30	60
260	29352 M	3	9	260	329	420	405	45	95
	29452 M	4	9	260	357	480	460	64	132
280	29256 M	2	9	280	323	380	370	30	60
	29456 M	4	9	280	387	520	495	68	145
300	29260 M	2	9	300	353	420	405	38	73
	29360 M	3	9	300	379	480	460	50	109
320	29264 M	2	9	320	372	440	430	38	73
	29364 M	3	9	320	399	500	482	53	109
340	29464 M	4	9	320	435	580	555	75	155
	29268 M	2	9	340	395	460	445	37	73
340	29368 M	3	9	340	428	540	520	59	122
	29468 M	4	9	340	462	620	590	82	170
360	29272 M	2	9	360	423	500	485	44	85
	29372 M	3	9	360	448	560	540	59	122
360	29472 M	4	9	360	480	640	610	82	170
	29276 M	2	9	380	441	520	505	42	85
380	29376 M	3	9	380	477	600	580	63	132
	29476 M	4	9	380	504	670	640	85	175

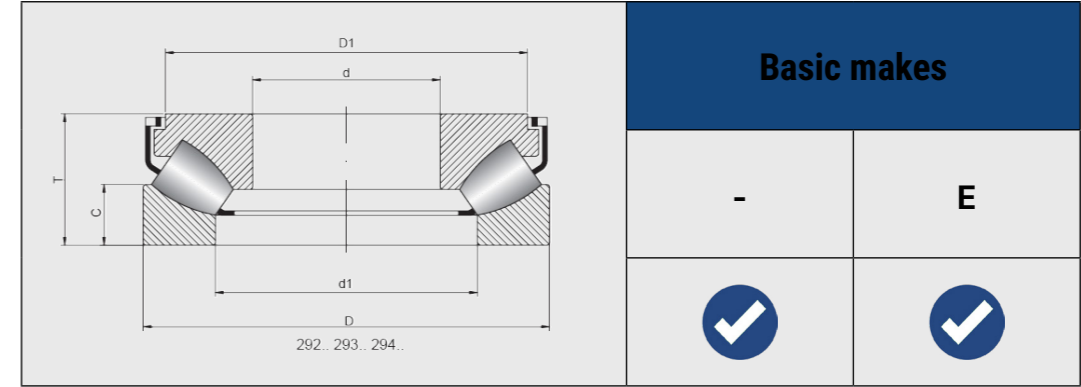

Weight (kg)	Basic load ratings (kN)		Limiting speed (rpm)		Bearing No.
	dyn. C	stat. C0	grease	oil	
80	2990	10200	560	750	29448 M
18,5	838	3720	-	1100	29252 M
51,5	2220	8300	600	800	29352 M
104	3510	12900	500	670	29452 M
19,5	862	4020	-	1000	29256 M
134	4310	15300	480	630	29456 M
30,5	1070	4890	-	900	29260 M
75,4	2670	10600	530	700	29360 M
32,9	1110	5170	-	850	29264 M
80	2880	11200	500	670	29364 M
175	4950	19000	430	560	29464 M
33,6	1150	5300	-	850	29268 M
96,3	2710	11000	480	600	29368 M
221	5750	22400	390	530	29468 M
51,8	1460	6450	-	750	29272 M
101	2760	11600	470	620	29372 M
231	5350	21200	360	500	29472 M
52,8	1580	7430	-	700	29276 M
129	3340	14000	450	530	29376 M
261	5870	24000	340	480	29476 M

EDITORIAL TEAM

Đuro Grabež

Chief Editor / Project Lead

Mile Mijušković

Chief Managing Editor

Filip Paško

Chief Technical Editor

Predrag Djukić

Technical Editor

© [Z&S Bearings Production], [2026].

All rights reserved. No part of this publication may be reproduced, distributed, transmitted, stored in a retrieval system, or otherwise used in any form or by any means—electronic, mechanical, photocopying, recording, or otherwise—without the prior written permission of the author.

This publication is protected by applicable copyright laws of the Republic of Serbia and international copyright conventions.

CIP - Katalogizacija u publikaciji
Biblioteke Matice srpske, Novi Sad
SPHERICAL roller bearings catalogue [Elektronski izvor] / [chief editor Đuro Grabež]. -
Temerin : Živko & Sinovi, 2026
658.114:621.822.6(497.113 Temerin)(085)
ISBN 978-86-83318-05-6
a) Živko i Sinovi (Temerin) -- Katalozi
COBISS.SR-ID 186707465

Committed to Quality Since 1992

AFI City Zmaj, 11000 Belgrade, Serbia
+381 11 7753757
office@zs-bearings.com
zs-bearings.com

© Z&S Bearings, Edition 2026



AFI City Zmaj, 11080 Belgrade, Serbia

+381 11 7753757

office@zs-bearings.com

www.zs-bearings.com